

INDUCTION

hobs

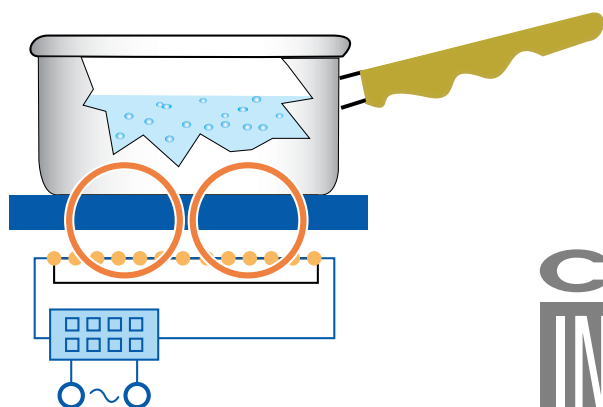

class
INDUCTION

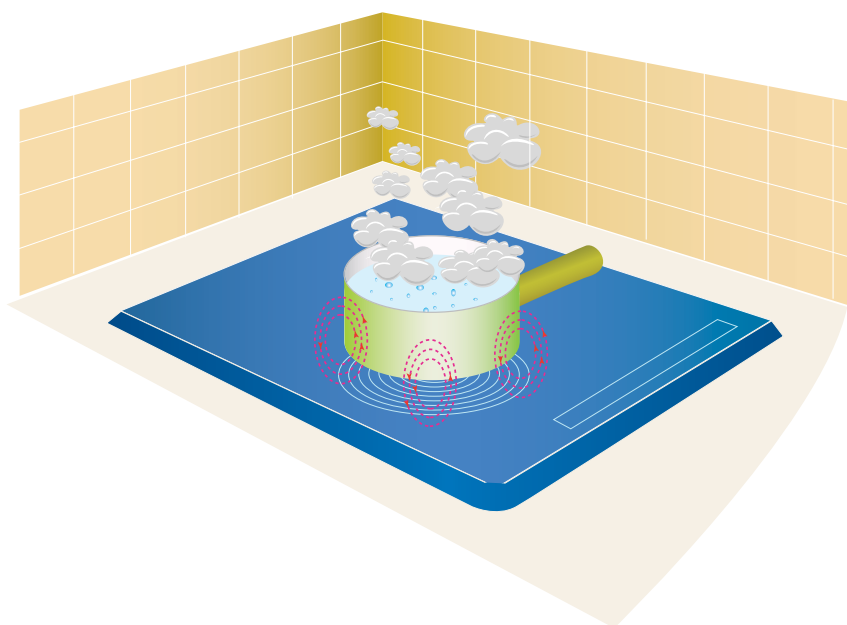

FAGOR  **BRANDT**

A FAGOR GROUP COMPANY

Recommended Troubleshooting & Repairing Guide:

	<p><u>V3.0 –LED & LCD TV Repair Tips ebook</u></p> <p>“More information on T-con Board & Mainboard Secret Repair Tips!”</p>	 <p><u>V2.0- LCD TV Repair Tips & Case Histories</u></p>
	<p><u>V1.0- Collection of LCD TV Repair Tips</u></p>	 <p><u>Vol-3 LCD/LED Monitor Repair Case Histories by Jestine Yong</u></p>
	<p><u>LCD/LED & 3D TV Repair Membership Site</u></p>	 <p><u>Plasma & 3D TV Repair Membership Site</u></p>
	<p><u>Projection TV & DLP/LCD Projector Repair Membership Site</u></p>	 <p><u>Troubleshooting & Repairing LCD TV Guide</u></p>
	<p><u>Plasma TV Repair Guide- Display Fault Troubleshooting Basic</u></p>	 <p><u>LCD TV Repair Secrets Revealed</u></p>
	<p><u>LCD Monitor Repair Guide</u></p>	 <p><u>Vol .1- 10 Trus Repair Case Histories of LCD Monitor</u></p>
	<p><u>SMPS-Switch Mode Power Supply Repair Guide</u></p>	 <p><u>Testing Electronic Components like a Pro- For Beginner</u></p>

Please visit: <http://lcd-television-repair.com/newsletter/Recommend.html>

1 - INTRODUCTION	5
2 - THE OPERATING PRINCIPLE	7
2.1. - Analogy with the transformer	7
2.2. - Skin effect	8
3 - THE PERFORMANCES	9
3.1. - Compared efficiencies	9
3.2. - Exceptional high speed	9
3.3. - Savings	9
3.4. - Information	9
3.5. - Safety	9
4 - THE SAUCEPANS	10
4.1. - Compatible containers	10
4.2. - Class induction	11
5 - INSTALLATION.....	12
5.1. - Flush mounting	12
5.2. - Ventilation	12
5.3. - IX6 ventilation	13
5.4. - Electrical connection	14
6 - USE.....	15
6.1. - Possible accesses	15
6.2. - Available powers	16
6.3. - 'Booster' function	17
6.4. - "STARTCONTROL"	17
6.5. - Safety devices.....	18
6.6. - Cooking guide	20
6.7. - Service	21
7 - OPERATING STEPS.....	22
7.1. - Block diagram	22
7.2. - Keyboard.....	22
7.3. - Filtering	22
7.4. - Rectifier	23
7.5. - Inverter	23
7.6. - Control.....	24
8 - THE MAIN COMPONENTS.....	25
9 - THE IX1 AND IX2 HOBS.....	28
9.1. - Description	28
9.2. - Fault codes	28
10 - THE IX3 HOBS	29
10.1. - Description	29
10.2. - Internal organization	30
10.3. - Details of the power circuit.....	30

11 - THE IX3WR HOB **31**

 11.1. - Description 31

 11.2. - Internal organization 32

 11.3. - Details of the power circuit 32

12 - THE IX4000 HOB **33**

 12.1. - Description 33

 12.2. - Internal organization 33

 12.3. - Details of the power circuit 34

13 - THE IX6 HOB **35**

 13.1. - Introduction 35

 13.2. - Internal organization 36

 13.3. - Power circuit description 37

14 - AID TO DIAGNOSTIC **38**

 14.1. - The glass-ceramic breakages 38

 14.2. - The 'error' codes 40

 14.3. - Tests and measurements on IX3, IX3WR, IX4000 and IX6 41

 14.4. - Measurements and checks on IX3 WR power board 43

 14.5. - Troubleshooting advice (IX3, IX3WR and IX4000) 44

1 - INTRODUCTION

There are two techniques of glass-ceramic heating:

- The infrared.
- The induction.

These glass-ceramic hobs are as like as two peas.

The difference is only obvious once hobs are turned on.

The infrared one glows red while the induction doesn't seem to operate.

The first is provided with radiant or halogen sources that transmit heat by radiation and conduction.

The second feeds a magnetic source, an inductor, which is placed under the glass-ceramic surface and transforms the magnetic energy into heat.

The traditional electrical hotplate is based on thermal conduction, while induction is based on the principle of the electromagnetic field.

The principle of heating by induction is a natural phenomenon discovered in the 19th century by several physicists, among whom Léon Foucault. He highlighted the development of currents facing the magnetic field in a moving metallic mass or a fixed metallic mass run through by a variable magnetic flux. These eddy currents in comparison to short-circuits cause a heating effect (Joule effect) in the mass.

Only since the middle of the 20th century induction started being used as a heating means, mainly in industries like the steel (induction furnaces). Induction only found its place in kitchens in the 80s, or even 90s for domestic electrical appliances with the marketing of the hob named IX1. The IX2 generation followed in 1992, IX3 (1996), IX3WR (2000) and currently IX4000 (2002) and IX6 (2005) generations.

The operating principle is innovating. Contrary to other cooking modes, it is the container itself, which heats and not the hob.

You put a saucepan down and this is sufficient to initiate the heat while the hob remains cold. The heating element is nothing but the container metal, which transforms the magnetic energy into thermal energy.

Induction qualities are flexibility, low inertia, easy cleaning, good efficiency and thermal safety. Induction enables a litre of water to boil in two minutes, milk to heat without overflowing and chocolate to melt just as desired. Induction efficiency may reach up to 90% according to the types of cooking. With such a technique, only the container heats. Inertia is therefore low and, above all, the plate temperature never exceeds the saucepan temperature.

Stepping from the mildest temperature to the strongest power, in an instant and while diffusing heat in a homogeneous way, attracts more and more consumers.

This technology is incomparable to those of present due to the induction method.

2 - THE OPERATING PRINCIPLE

2.1. - Analogy with the transformer

An induction hob operates due to the electromagnetic properties of most containers used on traditional hobs.

one can compare this hob with a transformer of which the secondary winding would have been shorted. A significant internal current arises therein and causes quick heating.

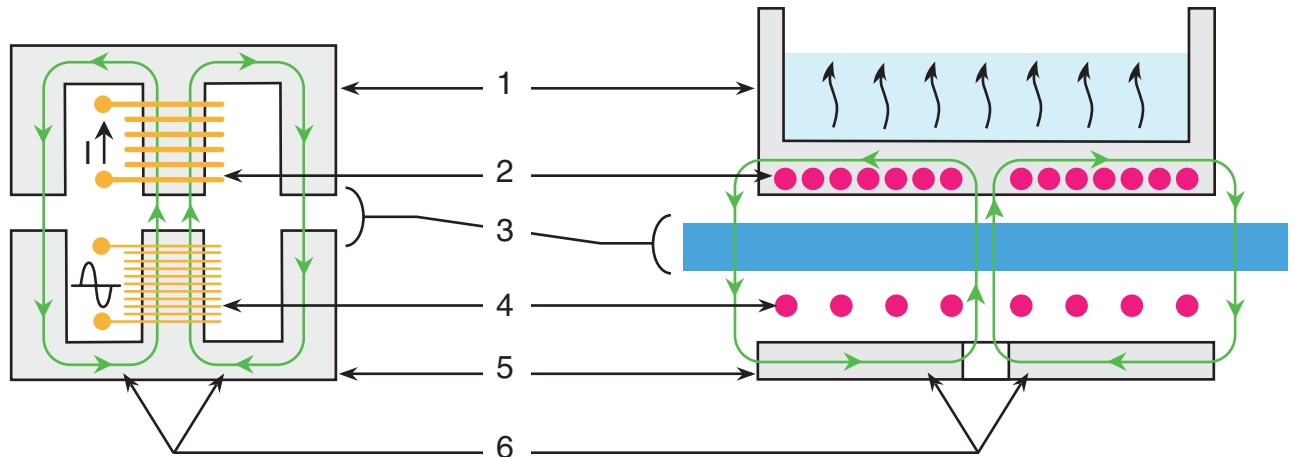

TRANSFORMER		INDUCTION HOB
Magnetic conductor	1	Saucepan
Secondary winding shorted	2	Saucepan
Gap	3	Glass-ceramic plate
Primary winding	4	Inductor
Magnetic conductor	5	Ferrite
Magnetic field	6	Magnetic field

The saucepan can be compared with a shorted set of concentric whose internal resistance is not zero.

From the function keys, you control the electrical power supply to the transformer primary winding which generates a magnetic field. This field induces currents at the bottom of the container placed on the hob. These induced currents heat the container immediately, which transmits the produced heat to the food inside. Cooking is performed efficiently with almost no loss of energy. The appliance heating power is pushed to its maximum.

2.2. - Skin effect

An induced current in a metallic mass will only cause significant heating if it flows through a significant resistor ($P=RI^2$). A ferrite saucepan has only low resistivity. This is where a second natural phenomenon occurs, which is called 'Skin effect'.

2.2.1. - Definition

The propagation of the high-frequency current is not performed in the same way as a direct current. Contrary to direct current, where current flows with consistency in a conductor, in HF its density varies and decreases exponentially as you move away from the conductor surface.

➤ Example on copper wire supplied with high frequency

The current flows predominantly in wire periphery 'e'. The decrease in the effective cross-sectional area of the conductor causes an increase in its resistance.

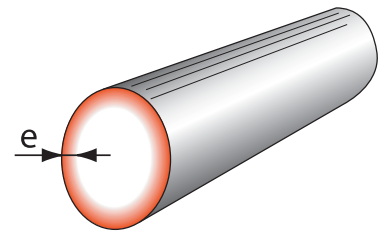

2.2.2. - Application

At a 20KHz frequency, and for a steel saucepan (magnetic ferritic material), the thickness of the saucepan in which the induced currents flow is approximately 35 μm . This allows generating a current in only a part of the saucepan bottom. The resistance becomes significant and the heating consequent therein.

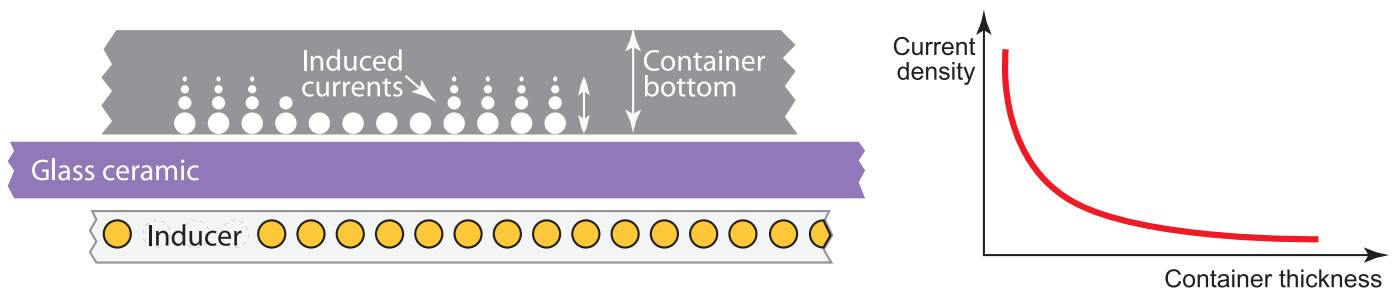

For a non-ferritic material, such as aluminium, the thickness is approximately 590 μm , the saucepan behaves then as a quasi-zero resistor (short-circuit), which is prejudicial to electronics. The board will take this discrepancy into account and will display the phenomenon by making the control panel flash. Therefore, this type of material is not adapted.

3 - THE PERFORMANCES

3.1. - Compared efficiencies

The efficiency is the ratio that exists between consumed energy (gas or electricity) and energy converted into heat. Large differences exist between induction, range-top appliance, and other cooking modes. These efficiencies may vary depending on the diameter and quality of the container used.

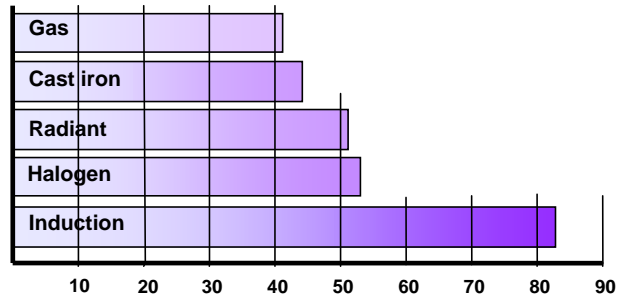

3.2. - Exceptional high speed

Thanks to the available power and high efficiency, this hob is much more rapid than an electrical or gas hob. **Time necessary to increase the temperature of two litres of water from 20°C to 95°C:**

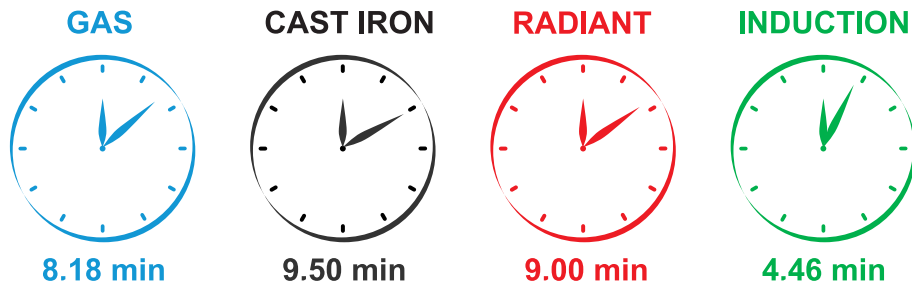

3.3. - Savings

Removing the container from a source is sufficient to stop the cooking immediately, there is no energy waste. As long as there is no container on a source, the source does not heat, the power indicator lights are flashing. This hob consumes thus much less energy than hobs fitted with traditional gas or electricity hobs.

3.4. - Information

Very flexible to use, it reacts instantaneously to controls. The power available on a source can vary from 50 to 2800 W (and more in certain cases!)

3.5. - Safety

The induction principle makes that heat is produced directly in the container. The temperature of the glass top is much lower and risk of burn is reduced, especially for children. **Return to 60°C after boiling of one litre of water:**

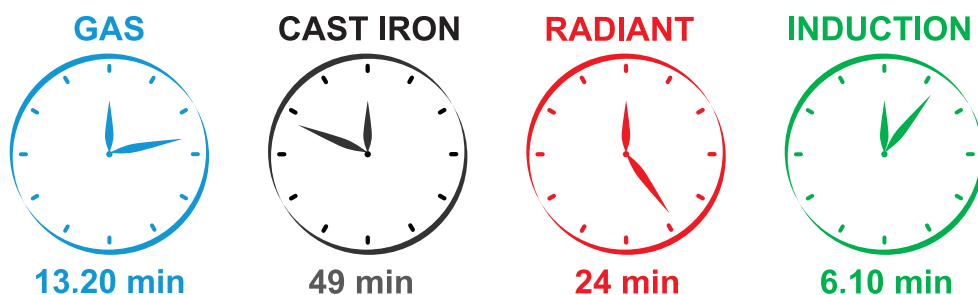

4 - THE SAUCEPANS

4.1. - Compatible containers

Induction requires appropriate saucepans.

As cooking is performed by magnetic field, conductive materials are necessary. A simple means is used to check whether an implement is compatible or not: **A magnet should stick to the bottom.**

During cooking, some pans can emit some noise (jangling). This is normal and due to the magnetic field. There is no risk, neither for the hob, nor for the pan.

The containers compatible with the induction are:

➤ **Containers in enamelled steel with or without non-stick coating.**

- Advantages:

- Compatibility guaranteed with induction (good efficiency)
- Low noise.
- Wide range of cooking possible.

- Disadvantages:

- Worse heat distribution pan diameters < 230mm.
- Cleaning is more difficult.
- Bad reaction if the pan is empty → bottom distortion, possible breaking of the enamel

➤ **Cast-iron containers with or without enamelled bottom.**

- Advantages :

- Compatibility guaranteed with induction (good efficiency)
- Good heat distribution (with low cooking power).
- Reduced noise of the pan.
- Easy cleaning
- Good to cook lovingly

- Disadvantages :

- The non enamelled bottom may scratch the glass.
- Bad reaction if the pan is empty → Cast iron doesn't move but can break.
- **Please note:** Do a preheating systematically before a full power cooking

➤ **Certain containers in stainless steel:** multilayer stainless steel, ferritic stainless steel. Most stainless steel containers are suitable if they pass the magnet test. (Saucepans, stew pots, frying pans, deep fryers...).

- Advantages :

- Very good heat distribution (For the pan with a stuck bottom).
- Good reaction if the pan is empty --> Stainless steel becomes blue
- Easy to clean.
- Wide range of cooking.

- Disadvantage :

- Bad heat distribution (For the pan without a stuck bottom).
- Compatibility is not always guaranteed: Some stainless steels give bad results.
- When the hob recognizes a poor reaction of the pan, the power is automatically reduced.

Advice: Use an enamelled pan to do some tests

- The pan is noisier.

➤ **Aluminium containers with special bottoms.**

- Aluminium containers are used more and more. Unfortunately, the quality and the thickness of the stainless steel are not always good.

Containers with a thick flat base for uniform cooking have to be decided upon (heat is better distributed).

Glass, earthenware, ceramic, copper and aluminium containers without special bottoms are not compatible.

- Choose, if possible, containers with very thick bottoms.
- Avoid any containers with rough (non-enamelled cast iron for example) or dented bottoms that might scratch the plate.
- Don't pull the containers, put them down.

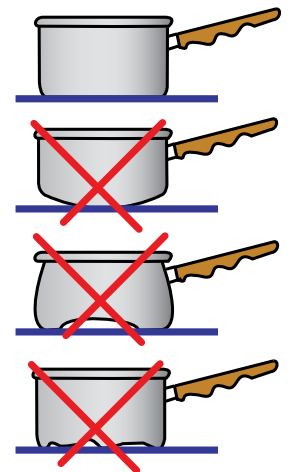

4.2. - Class induction

A "CLASS INDUCTION" marking, mark of excellence, appears on the hob. By choosing a container bearing the same logo, the consumer will make sure of the perfect compatibility with his/her induction hob, under normal operating conditions.

To help the consumer pick, a list of implements tested and approved is appended to the user manual.



5 - INSTALLATION

5.1. - Flush mounting

A minimum dimension shall be measured from the wall and sidewalls (back and/or sides).

- Protection of cuts: Chipboards used for making working planes inflate relatively rapidly in contact with humidity. Apply to the cut edge a varnish or special glue to protect it from steam or condensation waters that can rise under the working plane.
- A seal ensures watertightness with the working plane. It must be glued under the hob periphery.
- Clips supplied together with the hob are used to fix the hob.

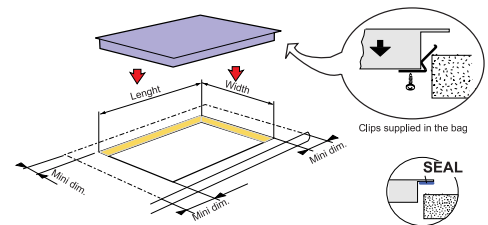

5.2. - Ventilation

Many after-sales department problems are related to bad ventilation. The induction hob is fitted with a cooling fan that sucks the air through the rear and discharges it to the front. It is necessary, during the installation, to scrupulously observe the recommendations provided by the user manual. Depending on the kitchen layout, the hob will be installed:

- Over a furniture with door or with drawer
- Over an oven of same brand
- Over an oven of other brand
- Over a dishwasher

It should not be fitted over a washing machine, refrigerator or a freezer.

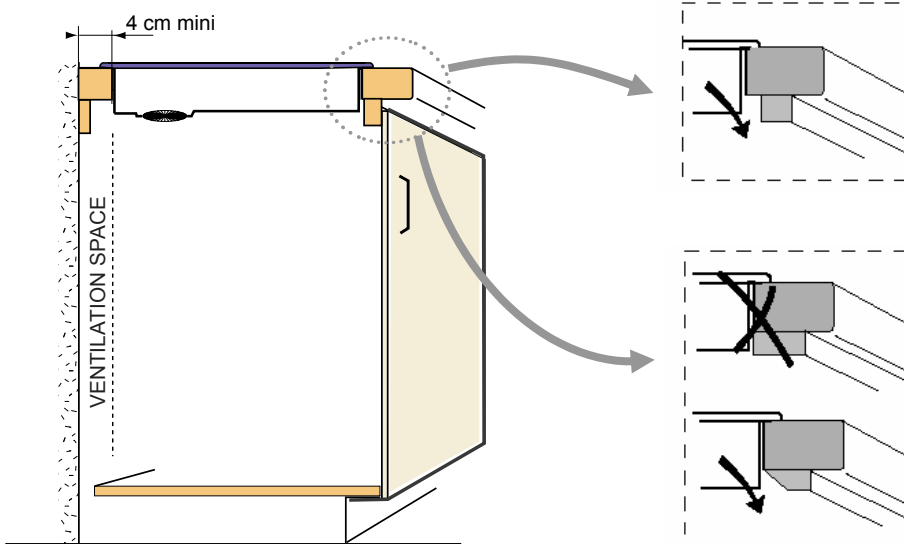

1- In the case of a small cross-piece, no special constraints.

2- In the case of a rectangular cross-piece or closed top, perform bevelled cutting to clear the air outlet.

3- In the case of a prolonged use of several sources simultaneously or of use in warm period, it is recommended you to drill lateral orifices in the sides of the furniture, at the front, to provide better evacuation of the hot air. 40 cm² minimum.

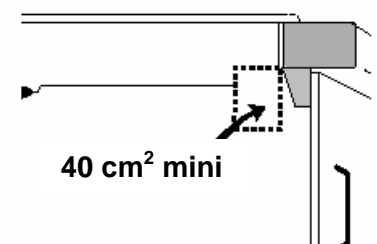

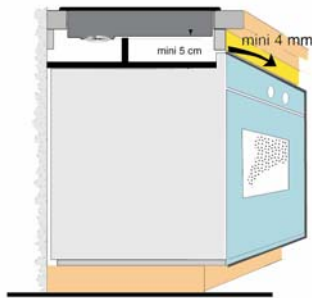

Oven in down position

Over an oven of other brand: The installation should guarantee fresh-air inlet at the rear and outlet at the front, and the oven shall be isolated from the hob

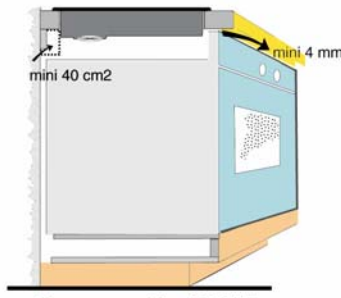

Oven in up position

Over an oven of same brand: The installation should guarantee fresh-air inlet at the rear and outlet at the front.

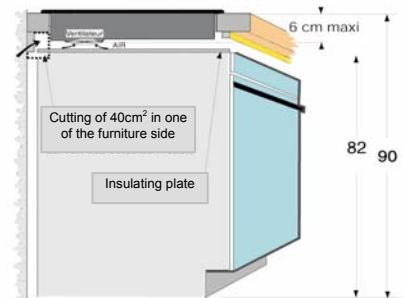

Over a dishwasher : It is necessary to cover the dishwasher top with an insulating plate supplied together with the hob. A minimum fresh-air inlet shall be provided.

5.3. - IX6 ventilation

To allow good ventilation in several conditions, the **IX6** hobs use a new bottom cabinet. The front holes cannot be shut by the worktop. (This new cabinet is also used for IX4000 models since June 2005).

➤ **Over a furniture with door or drawer**

The installation shall guarantee fresh-air inlet at the rear and outlet at the front

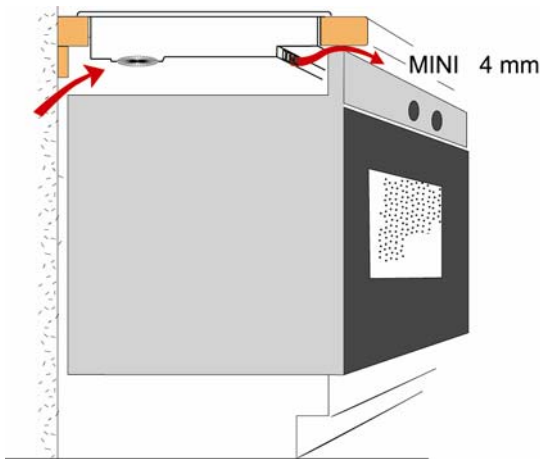
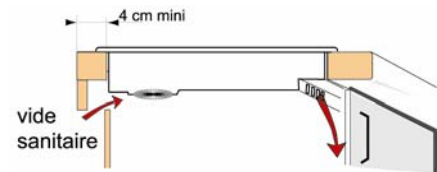

➤ **Over an oven of the same brand**

The installation should guarantee fresh-air inlet at the rear and outlet at the front.

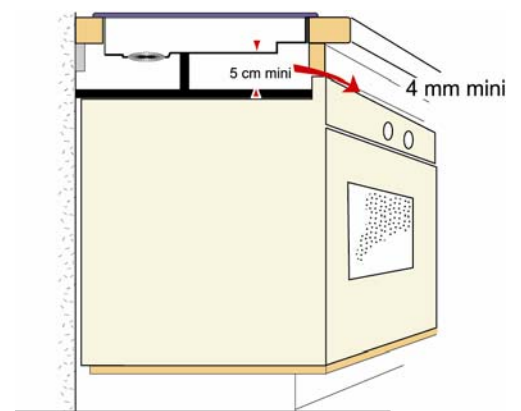

➤ **Over an oven of other brand**

The installation must guarantee fresh-air inlet at the rear. The front outlet must 4mm minimum and the oven must be insulated from the hob (Distance 5cm minimum)

➤ **Au-dessus d'un lave-vaisselle**

It is necessary to cover the top of the dishwasher with a plastic sheet (ASS reference 75X1652).

Ensure a fresh air inlet and a front outlet of 4mm mini.

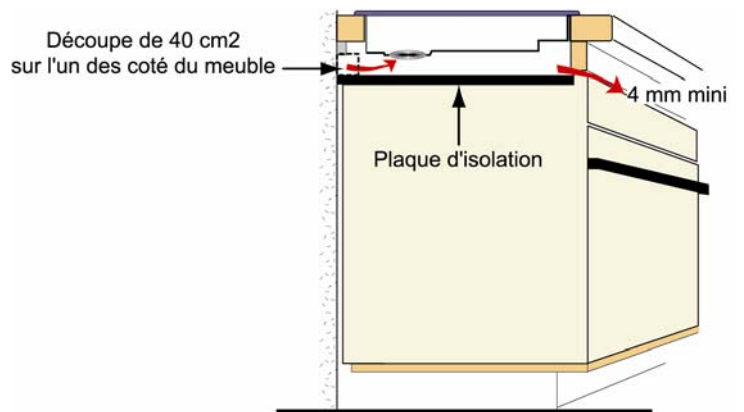

5.4. - Electrical connection

Hobs with three or more sources have five wires to be connected. Wires other than the yellow/green shall be connected in pairs to a 32 Amp connector (connector specific for cooking).

Hobs loosely fitted, with connecting block or combined with gas can be connected to a 16 A connector (Conventional connector).

400V Triphase

Connect the 4 wires to the installation respecting the wire colours

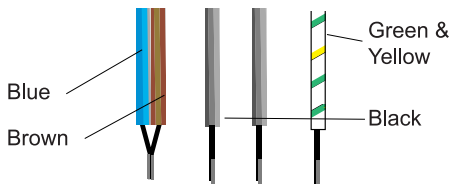

The fuse must be **16 Amps**



Note :
Separate the 2 live wires L1 L2 before connecting

Single phase 230V

Connect the 3 wires to the installation respecting the wire colours

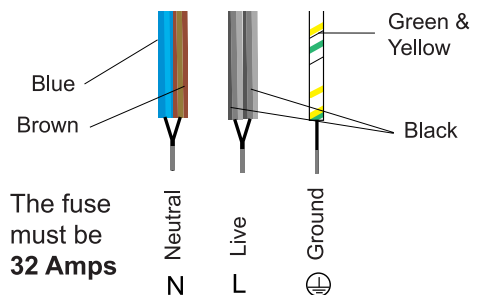

The fuse must be **32 Amps**

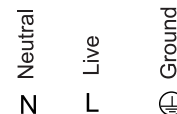

If the user has three-phase power supply, the connection can be distributed over two phases by separating the black wires of the 5-way cord.

The advantage is to work only with a 16A protection.

On hob power-up or after prolonged power cut, a luminous code is displayed on the keyboard. It disappears automatically after 30 seconds, or from the first action on any one key on the keyboard.

In case a appliance is used, which would not be grounded or would include a defective ground connection, the manufacturer's responsibility would not be committed

6 - USE

6.1. - Possible accesses

<p>IX6 : Keyboard with capacitive keys, including three keys for access to defined powers 6, 10 and 12, an ON/OFF and keys to adjust the power step by step.</p> <p>On the right, the timer can be set the + and – keys</p>	
<p>IX6 : Keyboard with capacitive keys including three keys for access to defined powers 7, 11 , 15, plus a "Boost" key for a full power adjustment</p> <p>On the right, the timer can be set the + and – keys 2 other keys "STARTCONTROL" to program a delayed start..</p>	
<p>Keyboard with capacitive keys, including three keys for access to defined powers 6, 10 and 12, an ON/OFF and keys to adjust the power notch by notch.</p>	
<p>Keyboard with capacitive keys. Power distribution on 9 levels. Power display on a single 7-segment display.</p>	
<p>Keyboard with microswitches, including three keys for access to defined powers 6, 10 and 12, an ON/OFF and keys to adjust the power notch by notch. Three zones of colours: Green-Orange-Red.</p>	

6.2. - Available powers

Induction hobs propose 9, 12 or 15 power levels on each source, usually comprised between 50 and 2800 W. Certain sources (triple crown or Krône) integrate a booster function that provides a power of 3200 or 3600 Watts.

➤ Example of control with 12 levels

1	2	3	4	5	6	7	8	9	10	11	12
50W	100W	200W	300W	400W	500W	750W	1000W	1250W	1500W	2000W	2800W
Alimentation 500W découpé					Power supply with variable frequency						

➤ Example of IX6 control with 13 levels and with a 160 mm diameter

1	2	3	4	5	6	7	8	9	10	11	12	13 or 
50W	100W	150W	250W	350W	500W	650W	800W	950W	1150W	1400W	1800W	2200W
Clipping 500W power supply						Power supply with variable frequency						

➤ Example of IX6 control with 13 levels and with a 180 mm diameter

1	2	3	4	5	6	7	8	9	10	11	12	13 or 
50W	100W	150W	250W	350W	500W	650W	800W	950W	1150W	1400W	1800W	2800W
Clipping 500W power supply						Power supply with variable frequency						

➤ Example of IX6 control with 13 levels and with a 210 mm diameter

1	2	3	4	5	6	7	8	9	10	11	12	13 or 
50W	100W	150W	250W	350W	500W	650W	800W	950W	1150W	1400W	2000W	3100W
Clipping 500W power supply						Power supply with variable frequency						

➤ Example of IX6 control with 13 levels and with a 280 mm diameter

1	2	3	4	5	6	7	8	9	10	11	12	13 or 
100W	200W	300W	400W	500W	600W	800W	1000W	1200W	1400W	1800W	2800W	3600W
Clipping 500W power supply					Power supply with variable frequency							

The returned power is variable according to the saucepan dimensions and nature. The above values have been obtained with an enamelled sheet metal saucepan of 210mm diameter.

- For a power lower than 500W (1 to 5), the power varies by clipping the 500W.
- From 500W to 2800W (6 to 12), the power varies by frequency variation (50KHz for 500W and 25KHz for 2800W).

Caution: A generator can feed two sources. If these two sources are operating simultaneously, the maximum power will be limited due to the power distribution between front and rear. The distribution is performed either by relays (IX1,2,3 and 4000), or by transistors (IX3WR and IX6).

6.3. - 'Booster' function

This function concentrates the maximum power on only one inducer. The "Boost", "MAX" or "Express" function are not made to cook during a long time but for a speed increase of the temperature in order to boil water for example.

Boost function atomically limits the power of the other inducer.

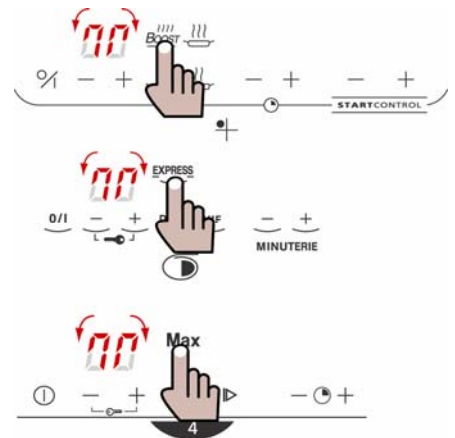

6.4. - "STARTCONTROL"

This function allows programming of the end-of-cooking time. It's necessary to set :

- **End of cooking time (24H possibles)**
- **A duration (99 min. maxi)**
- **A cooking power (limited at 6 in order to cook lovingly or keep warm)**

1. Press the 0/1 key "STARTCONTROL"



2. Display the clock by pressing +/- keys "STARTCONTROL"

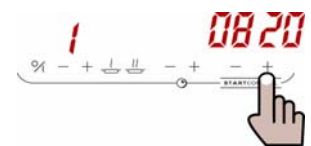

3. Set the cooking time
Example : 12h10
The inducer's power displays automatically

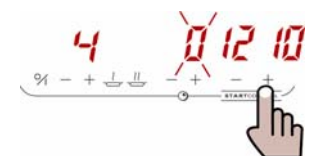

4. Set the **cooking duration**



5. It's possible to adjust the power



6. Parameters are registered; a "d" is displayed for few seconds and disappears.



Display lights up automatically when the start time has been reached and without "d". Press the on/off key to cancel the programming.

Examples of "STARTCONTROL" uses :

Dish	Container	Lid	Power	Duration
Mashed potatoes	Casserole	Yes	4	12 min
Cooked rice, Pasta	Casserole	Yes	4	8 to 9 min
Soup (2 plates)	Casserole	Yes	5	10 min
Cooked vegetables	Poêle	Yes	4	10 to 12 min
Milk chocolat (1 mug)	Casserole	No	4	10 min

6.5. - Safety devices

6.5.1. - Residual heat

The latest models propose a "top hot" display. After intensive use, the cooking zone can remain hot for a few minutes. An "H" (indicator of residual heat) is displayed during this period.

6.5.2. - Automatic stop

As soon as the saucepan is removed from the source, the power supply is cut.

In the event a container is forgotten, a safety device named 'Automatic Stop' can act. The allowed operating time varies according to the power. The heating-zone display will show 'A' or 'AS' and an audible beep will be emitted for two minutes.

9-level power	12-level power	15-level power	Auto. Stop after
1 to 4	1 to 7	1 to 9	8 hours
5 to 7	8 to 11	10 to 14	2 hours
8 to 9	12 + boost	15 + boost	1 hour

6.5.3. - Children safety device

On certain models, the controls can be locked:

- Either when off.
- Or during use (the current operations subsist and displayed settings remain active).

However in locked position, for safety reasons, the "off" key has priority and cuts the source supply. The small illuminated '0' goes off after a few seconds.

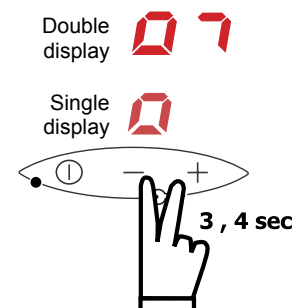

6.5.4. - Information keeping

- Power cut: information lost after four minutes.
- Absence of non-compatible saucepan or container: Source cut after one minute.
- On/Off: if there is no other information, source cut after 30 seconds.

6.5.5. - Safety in case of overflow

In case of overflow, induction hob is equipped with a safety feature. This function allows an automatic switch off of the hob with signal '-' and an audible alert.

- Overflow covering the control keys.
- Wet towel covering the control keys.
- Metallic object put on the control keys

6.5.6. - "Small objects"

A small pan, a fork, a spoon or each other small objects are not detected as a container. The display flashes, no power is delivered.

6.5.7. - Pacemakers and active implants

The hob operation is in accordance with the standards on electromagnetic interference in force. The induction hob meets thus perfectly the legal requirements (directives 89/336/CEE). The hob is designed not to hinder the operation of other electrical appliances to the extent where they comply with the same regulations. An induction hob generates magnetic fields in its very close environment.

To prevent interference with a pacemaker, the pacemaker must be designed in accordance with the regulation concerning it. For any information regarding the conformance or no of a pacemaker, the consumer must get information from the manufacturer or his/her attending physician.

6.5.8. - Temperature limiter

Each inducer uses a NTC sensor measuring the container temperature through the glass. This system help protecting the hob and the containers against over heating (Pan without food for example).

In case of overheating, the temperature of the pan is regulated around **300°C**. This temperature does not allow the deterioration of the **PFTE** (anti sticking material used in the pans). Damages start above 340/350°C.

6.6. - Cooking guide

Follow the examples in the table and take into account that maximum powers are reserved for frying and quick bringing to the boil.

Symbols (legend opposite) placed in the table are used to optimize the hob use.

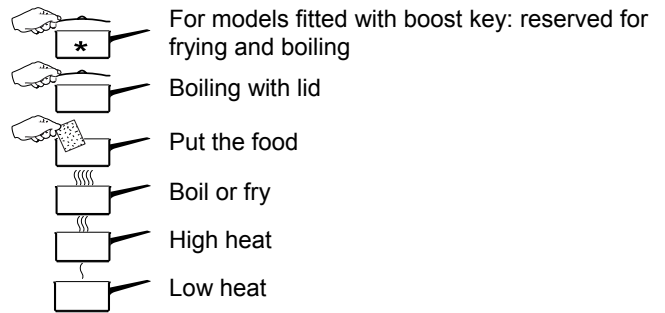

DISHES	HEATING POWER	FRYING AND BRINGING TO THE BOIL		COOKING / BROWNING BRINGING BACK TO THE BOIL STEADY SIMMERING				COOKING / SIMMERING			KEEPING WARM		
		12	11	10	9	8	7	6	5	4	3	2	1
SOUPS	BROTH												
	THICK SOUP												
FISH	STOCK												
	FROZEN												
SAUCES	THICK, MADE WITH FLOUR												
	MADE WITH BUTTER AND EGGS (BEARNAISE, HOLLANDAISE)												
VEGETABLES	CHICORY, SPINACH												
	PULSES												
	BOILED POTATOES												
	FRIED POTATOES												
	SAUTE POTATOES												
DEFROSTING VEGETABLES													
MEAT	THINLY SLICED MEAT												
	FRYING STEAKS												
	GRILLING (CAST IRON GRILL PAN)												
DEEP FRYING	FROZEN CHIPS												
	FRESH CHIPS												
MISCELLANEOUS	PRESSURE COOKER												
	SEWED FRUIT									(ONCE IT HISSES)			
	PANCAKES												
	CUSTARD												
	MELTING CHOCOLATE												
	JAM												
	MILK												
	FRIED EGGS												
	PASTA												
	BABY FOOD IN JARS (BAIN MARIE)												
	STEW												
	CREOLE RICE												
	RICE PUDDING												

6.7. - Service

Glass ceramic is a silicium-based material that does not expand like glass. Its dimensions do not practically vary up to 750°C, as a part of the molecules composing it expands under heat, while an equal number retracts. A feature of this material is that it is a poor heat conductor and therefore limits heat loss.

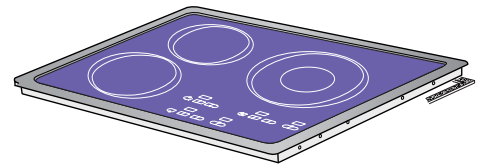

The plane surface of the glass ceramic and the sensitive controls make cleaning easy. The own cleaning difficulties of radiant and halogen sources are usually groundless on induction hob, owing to the low temperatures attained by the table. However, a saucepan with humid bottom put on the source leaves limestone traces. Sugar discharges should be cleaned immediately, as in contact with hot glass ceramic the sugar caramelizes. When cooling down, it retracts and attacks the coating. Lastly, the glass-ceramic hob is not a working plane and thus is easily scratched.



Powder



Abrasive sponge



Cream



Sanity sponge or special sponge for delicate crockery

- Always use a clean surface for cooking
- Immediately eliminate sugar-based stains and discharges, as they can attack the glass ceramic
- Avoid rubbing with abrasive materials
- Never use the hob as a working plane
- Never put paper or an aluminium container on the source.

➤ **Cleaning products**

Glass-ceramic tops stained by carbonized greases are easy to clean with specific products qualified and managed in After-sales Department:

- 94 X 3140: Scraper + Glazing silicon gel + Soft cloth.
- 94 X 3141: Gel refill for the above set.
- 71 S 0003: Non-metallic scraper.

7 - OPERATING STEPS

7.1. - Block diagram

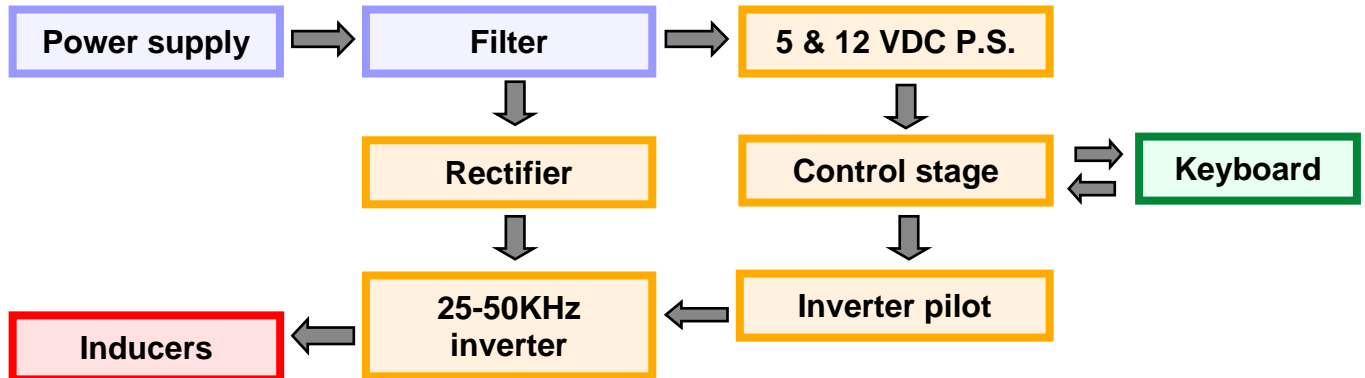

7.2. - Keyboard

There are two families of keyboards.

Microswitch keyboards can be entirely tilting or fixed protected by tilting covers. In both cases, a 'Keyboard operating' information is recorded either by a switch (tilting keyboard), or by the action of a magnet (tilting cover) on an I.L.S.

7.2.1. - Keyboards with capacitive keys (IX3, IX3WR, IX4000, IX6)

These keyboards provide a working plane without air inlet (and thus grease inlet).

The key activation is validated when the user's finger disturbs the high-frequency signal applied to a blade. For a good operation, each blade should be perfectly in contact under the glass ceramic.

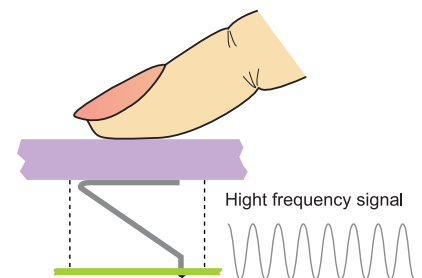

7.3. - Filtering

By design, the appliance can generate significant high-frequency interference. In order to guarantee a minimum interference level, an important filtering device is used. It enables induction hobs to be environment-friendly appliances, whose interference level is smaller than that of a television set.

The 'filtering' stage fulfils several missions:

- It protects from operating overcurrents
- It eliminates incoming and outgoing interference
- It eliminates overvoltages (voltage peaks)

For this purpose, the same components are almost always used: Filtering capacitors, fuse(s), VDRs, high-inductance choke coils and an indispensable grounding.

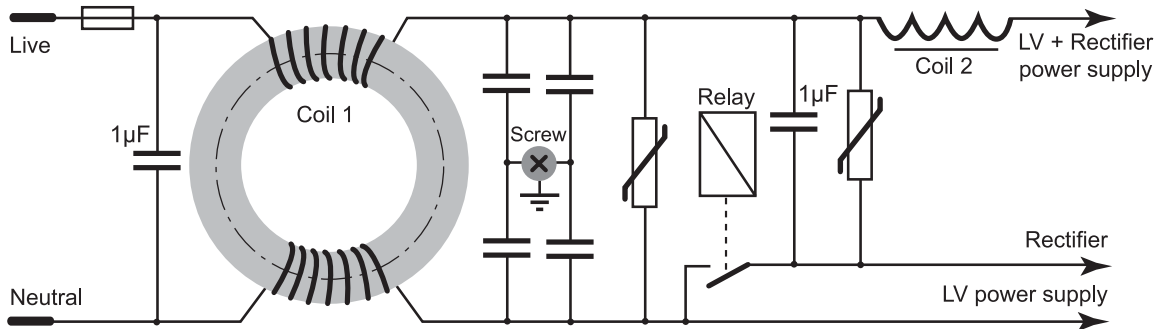

- VDR (Voltage Dependent Resistor) begins conducting at 275 or 420 Volts (according to the model) and eliminate voltage peaks.
- The fuse preventing overcurrents is done so using a restriction on the board pad (Fuse pad). Actually, there are two series-mounted fuses. Only the IX1 generation is protected by a cartridge fuse, it is a so-called 'Very rapid' fuse.
- Choke coils have a 'damping' role that only allows low frequencies. Their action is complemented by 1µF capacitors.
- The grounding is used to evacuate high-frequency interference 'residues'.

The screw attaching the filter has thus an essential role and shall be imperatively reinstalled after any action

7.4. - Rectifier

To supply the inducers, it is necessary to apply a high frequency. To change over from 50Hz to 50KHz it is first necessary to rectify the main voltage through a diode bridge. A filtering capacitor (of 5µF generally) is associated in order to attenuate the high-frequency signals. As shown by the illustration, the rectifier output voltage is approximately the main peak voltage (i.e. 310 VDC approx.) when no inducers are supplied. This voltage drops during the operation.

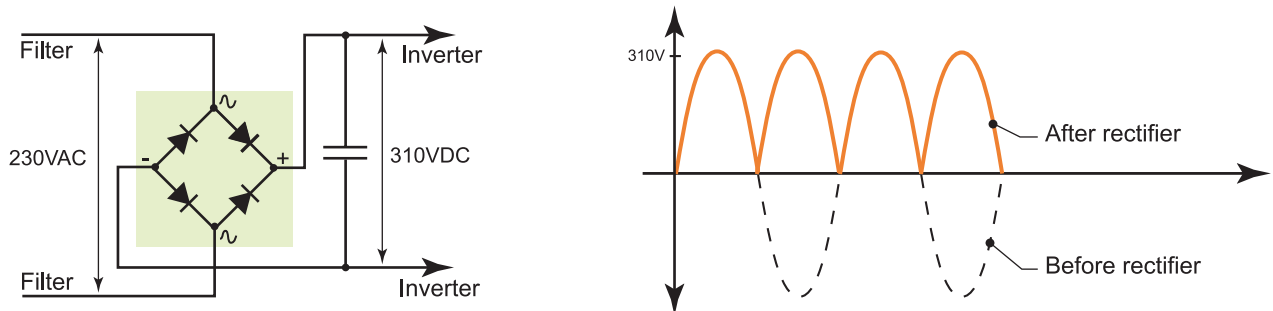

7.5. - Inverter

The inverter is used to transform a DC signal into an AC signal with adjustable frequency. The inverter consists of two transistors (whose technology can vary according to the hob generation), two capacitors and two recovery diodes (indispensable on any inductive circuit).

Transistors are frequency controlled by a generator. This frequency varies between 25KHz (for 2800W) and (50KHz for 500W).

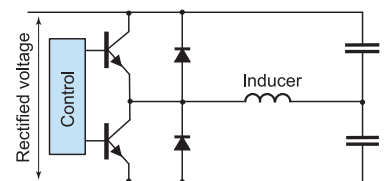

After establishment of a voltage on both capacitors, the operation can be broken down into four phases, as follows:

Phase 0	At rest	<p>Transistors T1 and T2 act as two open switches.</p> <p>Capacitors C1 and C2 are supplied and charged to a voltage $V/2$, the bridge is balanced, there is no current in the inducer.</p>	
Phase 1	Positive alternation	<p>Transistor T1 is controlled and acts as a closed switch.</p> <p>A current flows through the inducer while C2 is charged to $+V$ and C1 is discharged.</p>	
Phase 2	Positive alternation	<p>Both transistors are blocked but the inducer forces a current flow.</p> <p>C1 is charged again to $V/2$ and C2 is discharged down to $V/2$. The bridge is balanced again, => the current goes through 0 again</p>	
Phase 3	Negative alternation	<p>Transistor T2 is controlled and acts as a closed switch.</p> <p>A current flows in reverse direction in the inducer while C1 is charged to $+V$, and C2 is discharged.</p>	
Phase 4	Negative alternation	<p>Both transistors are blocked but the inducer forces a current flow.</p> <p>This is the recovery phase, where C2 is charged again to $V/2$, and C1 is discharged down to $V/2$, the bridge is balanced again, => the current goes through 0 again</p> <p>Return to step 1.</p>	

7.6. - Control

The entire operation is managed by a microprocessor.

- On generation IX1, a specific board performed the control; the power was managed by another board.
- On generation IX2, these two boards have been soldered and have become indissociable.
- On generations IX3, IX3WR and IX4000, power and control are entirely associated. So, the board integrates: A 5 and 12 VDC **clipping power supply** (which is also the keyboard power supply), the **control** part (in liaison with the control keyboard), the **rectifier** part, the **inverter** part, and lastly, for board IX4000 and IX6, the **filtering** part.

8 - THE MAIN COMPONENTS

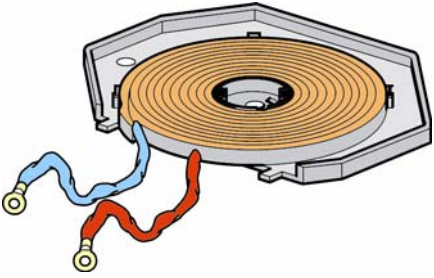
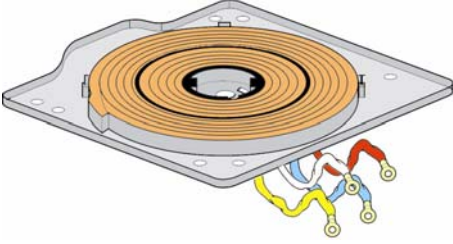
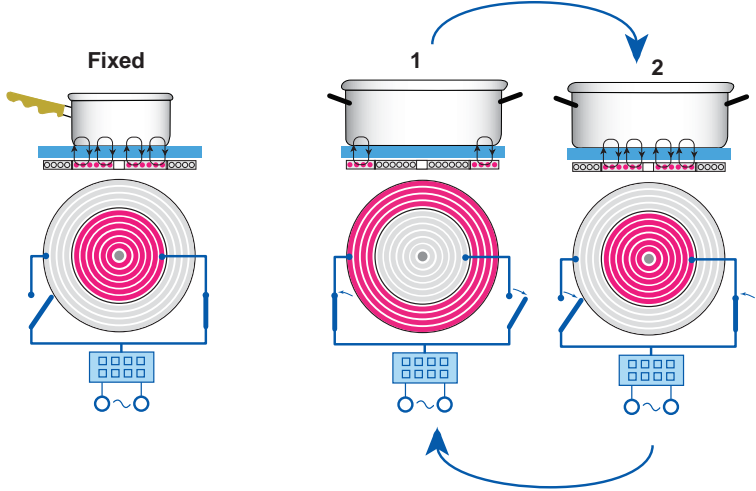
Designation	Function	Features												
<p>Single inducer</p> 	<p>This is a coil located under the glass ceramic, responsible for subjecting the magnetic field to the saucepan. It can have various sizes.</p> <p>A grounded screen limits the action of the magnetic field on the electronics. This screen integrates, in its lower section, magnetic ferrites whose role is to direct the field to the saucepan.</p>	<p>Simple coils can have various diameters:</p> <ul style="list-style-type: none"> • 16-cm diameter for small containers, 2000 or 2200W. The container must have 10cm minimum diameter. • 18-cm diameter, which is the most current dimension, 2000 or 2800W. 12cm minimum diameter of the container. • 21-cm diameter for larger-size containers, 2800W. 12cm minimum diameter of the container. 												
<p>« Krone » inducer</p> 	<p>The cooking zone recognizes and fits automatically the container diameter (12 to 32 cm) so as to deliver the optimum power, ensure excellent heat distribution in the container (Making of large-diameter pancakes, large-size fish such as sole or of large fricassees such as paella).</p> <p>A 'Booster' function is used to rise the maximum power (2800W) up to 3600W in order to bring rapidly to a boil a large quantity of liquid or of fat. (In this case, it is recommended not to exceed 5 to 6.5 min).</p>	<p>The Krône source operates as two independent sources under the same generator. The diameters are 18 and 28 cm, respectively.</p> <ul style="list-style-type: none"> • Pmax : 2800W • Booster : 3600W • Tables : IX3, IX3WR, IX4000, IX6 <p>The power distribution</p> <p>For saucepans with diameters comprised between 12 and 22 cm, the central source operates alone.</p> <p>For saucepans with diameters greater than 24 cm, a power distribution is performed between the central source and outer source:</p> <table border="1" data-bbox="1070 1294 1458 1435"> <thead> <tr> <th>Container ø</th> <th>Centre</th> <th>Outside</th> </tr> </thead> <tbody> <tr> <td>24 to 26 cm</td> <td>70 %</td> <td>30 %</td> </tr> <tr> <td>26 to 28 cm</td> <td>50 %</td> <td>50 %</td> </tr> <tr> <td>28 to 32 cm</td> <td>30 %</td> <td>70 %</td> </tr> </tbody> </table>	Container ø	Centre	Outside	24 to 26 cm	70 %	30 %	26 to 28 cm	50 %	50 %	28 to 32 cm	30 %	70 %
Container ø	Centre	Outside												
24 to 26 cm	70 %	30 %												
26 to 28 cm	50 %	50 %												
28 to 32 cm	30 %	70 %												
														

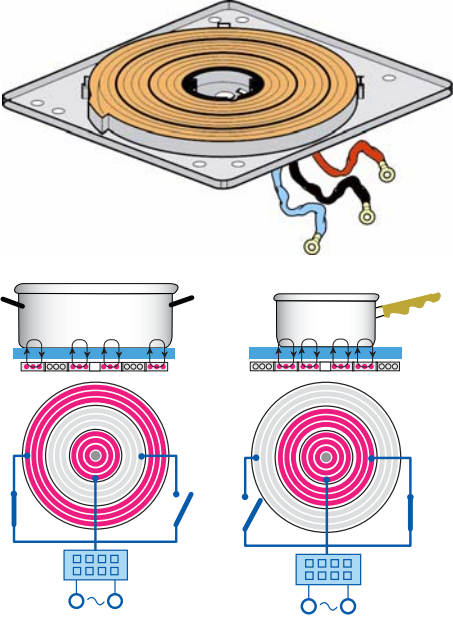
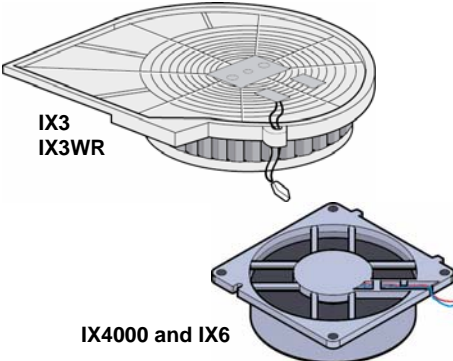
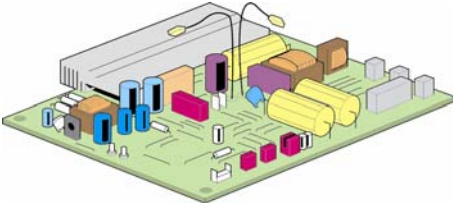
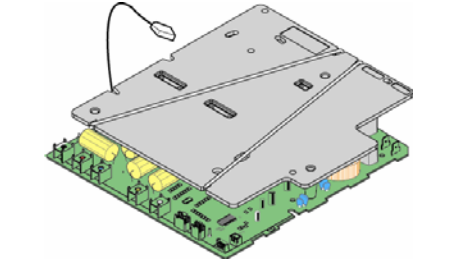
Designation	Function	Features
<p>Triple-crown inducer</p> 	<p>The cooking zone recognises and fits automatically the diameter of the container, 12 to 26 cm diameter, so as to:</p> <ul style="list-style-type: none"> • Deliver the optimum power corresponding to the container. • Give excellent heat distribution. • Provide a consistent cooking temperature 	<p>Inducer composed of 3 windings</p> <ul style="list-style-type: none"> • Diameter 1 : 6 cm • Diameter 2 : 10 cm • Diameter 3 : 22 cm <ul style="list-style-type: none"> • Pmax : 2800W • Booster : 3200W • Tables : IX3WR, IX6 <p>This source implies the use of a specific relay installed on the IX3WR power board. The generator always supplies two coils at a time but unlike the Krône source, there is no sequenced distribution between inside and outside: the board detects the presence or absence of a large-diameter source and defines its operating mode.</p>
<p>Fan</p> 	<p>Ensure cooling of electronic components located in the hob.</p> <p><u>Please note:</u> The fan voltage changes according to the temperature of the power board (measure by NTC probe).</p> <p>8V for 60°C 10V for 70°C 12V for 80°C</p> <p>The temperature read by the NTC is not the temperature inside the cabinet but the copper temperature.</p>	<p>Each generation of hobs is characterized by a different fan:</p> <ul style="list-style-type: none"> • IX1 : Tangential to 12VDC • IX2 : 12VDC • IX3,IX3WR : 230VAC, 23W, 270Ω • IX4000, IX6: 12VDC (PC type)
<p>Power board IX3WR</p>  <p>IX6</p> 	<p>The power board is used to manage the majority of the functions</p> <ul style="list-style-type: none"> - Rectification - Low-voltage power supply - Power supply to high-frequency inducers - Checks, using a microprocessor 	<p>The power supply frequency varies between 25kHz at maximum power and 50 kHz at 500W.</p> <p>The regulation between 50 and 500W is obtained by clipping the power supply. A power board is used to supply 2 sources or a double source.</p> <p>For this purpose, two features exist:</p> <ul style="list-style-type: none"> • one uses a single inverter with front/rear distribution relay (IX 1, 2, 3 and IX4000) • the other uses one inverter per source (IX3 WR) <p>Note: Hob IX1 is composed of a power board and a separate control board.</p>

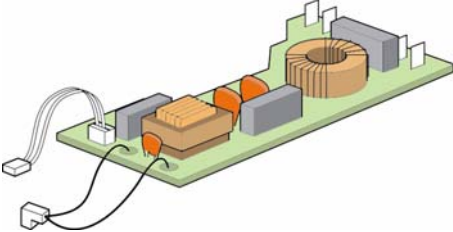
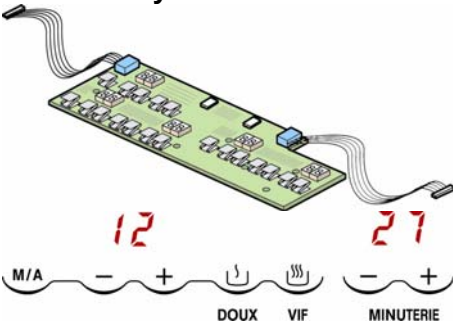
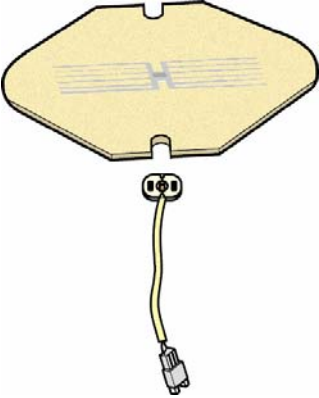
Designation	Function	Features
<p>Filter board</p> 	<p>The filter board is used to eliminate the voltage peaks originating from the mains (hob protection and to protect the mains from interference generated by inducers).</p>	<p>The filter board is composed of</p> <ul style="list-style-type: none"> • Several VDR • High-value choke coils • A power supply relay • A fuse (fuse pad) <p>On IX2, IX4000 and IX6, the filter board is integrated in the power board.</p>
<p>Keyboard board</p> 	<p>The keyboard board is used to control each of the sources. It is capable of integrating a timer for the rear source.</p>	<p>Each generation of hobs uses different keyboards. The communication with the power board is multiplexed.</p> <ul style="list-style-type: none"> • IX1 : 2 14- and 4-wire connections • IX2 : 2 14- and 6-wire connections • IX3 : 6-wire connections • IX3WR, IX4000, IX6: 8-wire connection (same control logic).
<p>Temperature sensor</p> 	<p>The temperature sensor is an NTC resistor. Its function is to determine a possible saucepan overheating, particularly in event of heating when empty (no heat dissipation)</p> <p>In event of overheating, a power cut-off is performed by the power board until reaching the moderate temperature of the source. This power cut-off is transparent for the user (no modification to setpoint)</p> <p>The temperature sensor is not used to detect the presence of a container</p>	<p>The NTC is housed in a heat collector (also called comb that is apparent or integrated between a plate of mica (IX3, IX3WR and IX4000) and an insulator.</p> <ul style="list-style-type: none"> • IX1, IX2, IX6 : 100 kΩ at 25°C • IX3, IX3WR and IX4000 : 33kΩ at 20°C

9 - THE IX1 AND IX2 HOBS

9.1. - Description

IX1: This first generation has been manufactured between 90 and 91. It is composed of four boards.

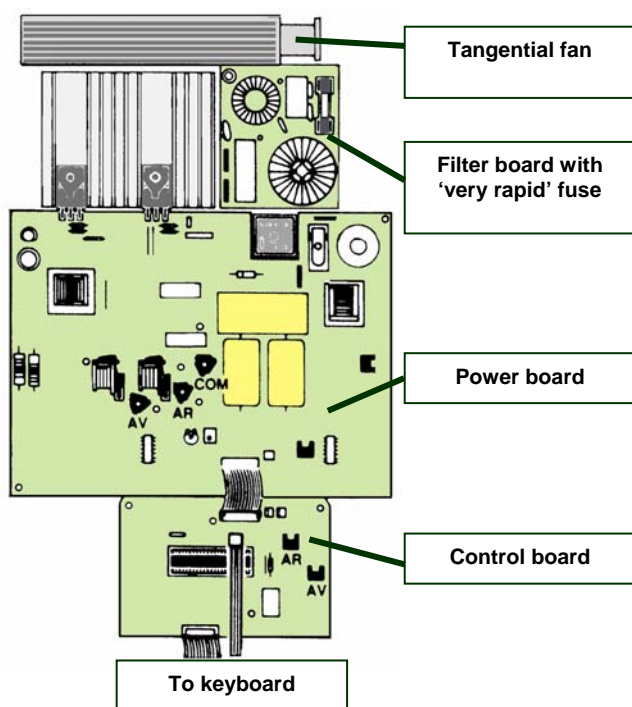

IX2: The second generation appeared in 92 and has been manufactured until 95. The ventilation was reviewed, 'filter' and 'power' boards have been associated.

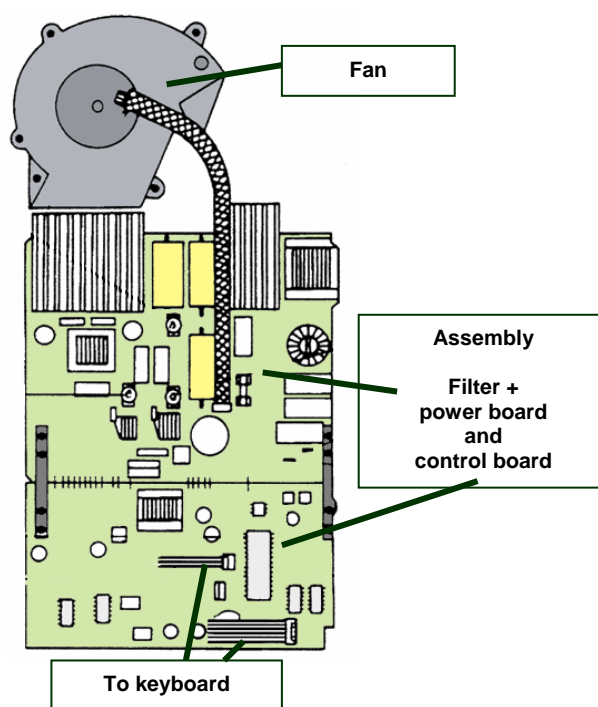

9.2. - Fault codes

F8	The NTC does not detect T°C rise > 5°C	Display after 2 min during MAXI selection on one of the sources.
o _o	Overheating and electronics putting into safety.	Check the installation Check the ventilation.
F0	Discrepancy detected by the Rear NTC	Room T°C < 5°C Check the assembly, connection and ohmic value of the NTC.
Fo	Discrepancy detected by the Front NTC	Room T°C < 5°C Check the assembly, connection and ohmic value of the NTC.

F0	T°C NTC < 3°C	Room too cold
F1 F2	Front source : Pb of shorted NTC (F1) or open circuit (F2)	Check the assembly, connection and ohmic value of the NTC.
F3 F4	Rear source : Pb of shorted NTC (F3) or open circuit (F4)	
F5 F6	Check of transistors: Pb of shorted NTC (F5) or open circuit (F6)	Replace the board as NTC's and transistors are interdependent
F7	Electronics T°C > 75°C	Check the installation Check the ventilation.
F8	Inversion of front and rear NTC's	
F9	Error in temperature measurement	Replace the board

10 - THE IX3 HOBS

10.1. - Description

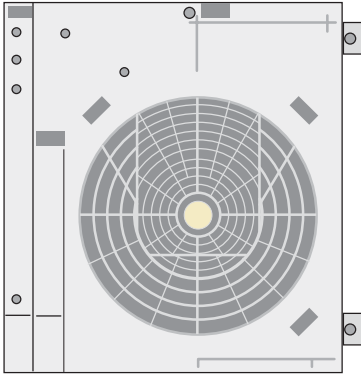

The hob of generation IX3 is identified by the presence of a mounting part that appears under the hob, ventilation part, and by its internal composition of two boards (filter and power), with the keyboard possibly having several various shapes, according to the brand and model.

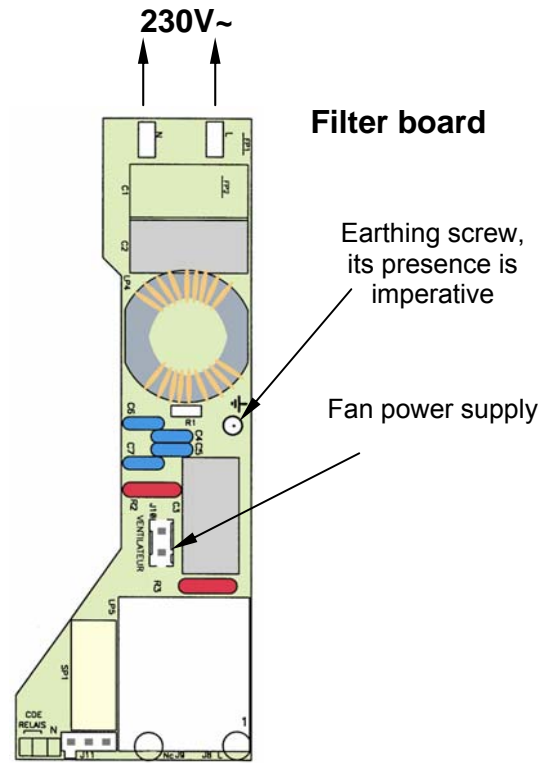

The IX3 operating principle is the same as IX1 and 2. When two inducers of the same generator are used simultaneously, the power is distributed by switching relays.

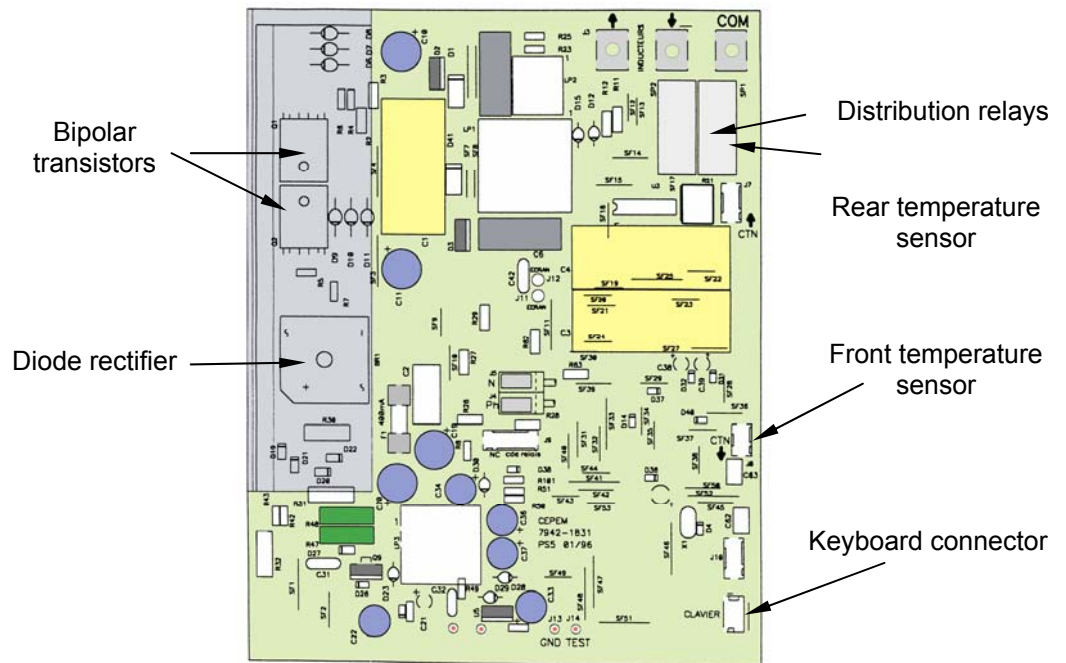

IX3 production has stop in 2005 and has been replaced by version IX4000. Standby consumption is under 3.5 Watts.

10.2. - Internal organization

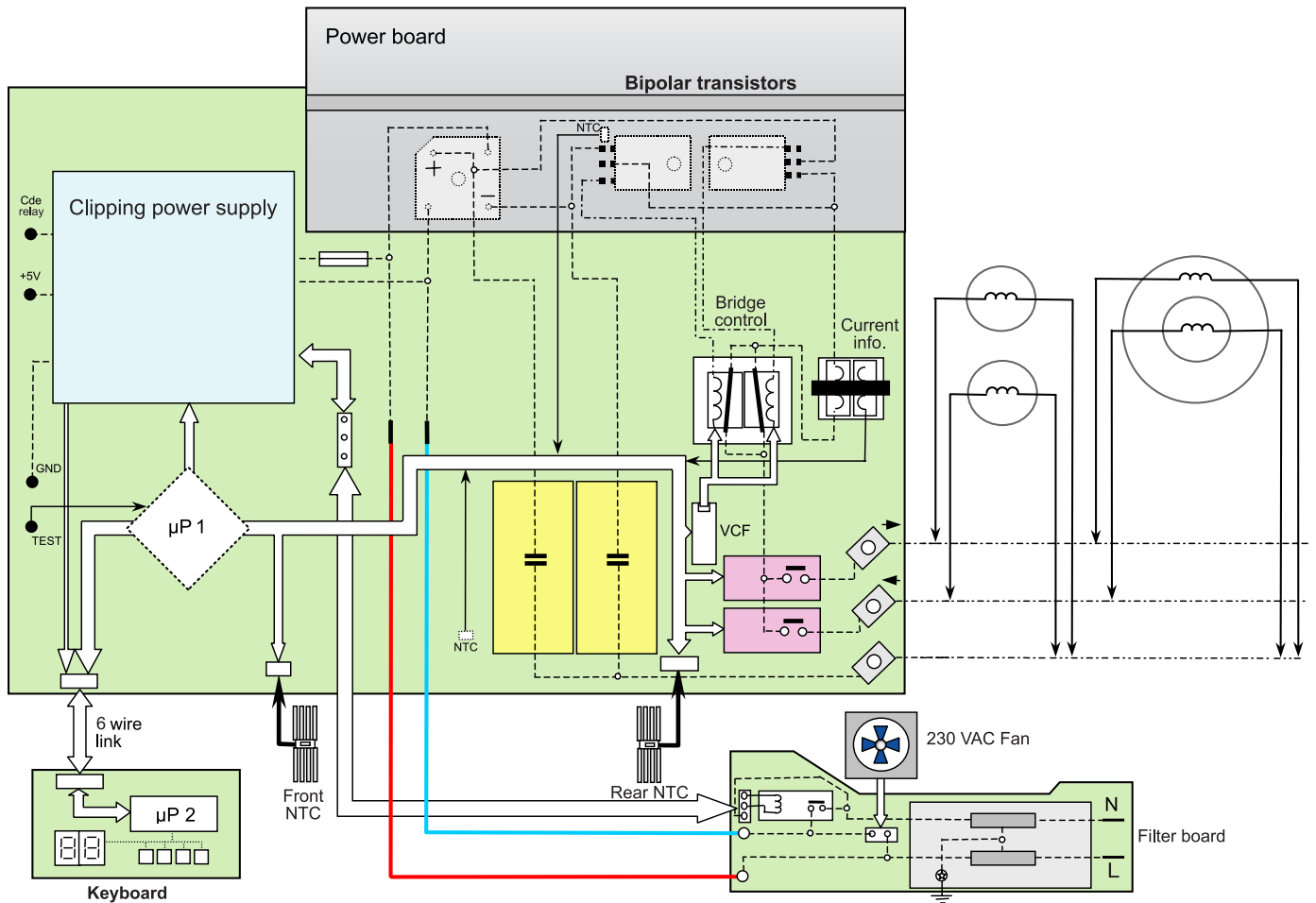

10.3. - Details of the power circuit

IX3 power circuit is organized like generations IX1 and IX2, namely:

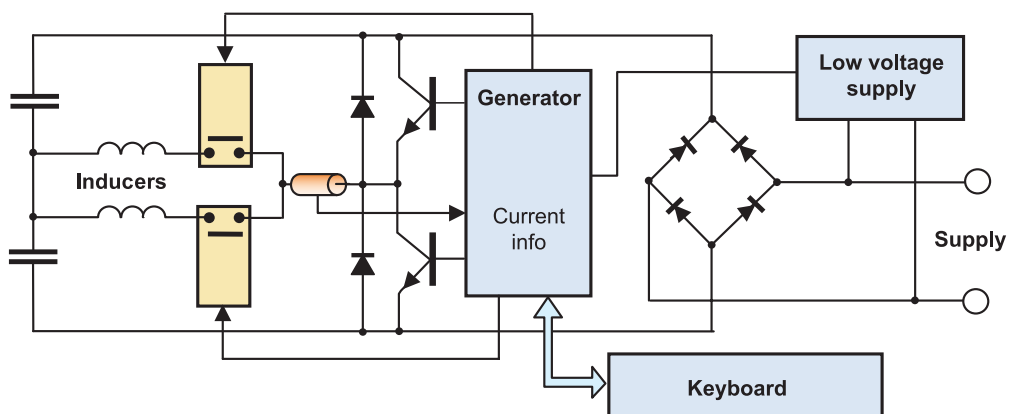

- Front / rear distribution by two relays.
- Saucepan detection using a current transformer. The measurement of current made is used to check the saucepan compatibility.
- Use of two bipolar transistors.
- Integrated rectifier bridge.

11 - THE IX3WR HOBS

11.1. - Description

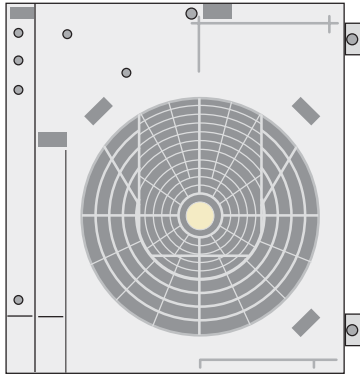

The hob of generation IX3 WR (like IX3) is identified by the presence of a mounting part that appears under the hob, the ventilation section, and its internal composition of two boards (filter and power), the keyboard that can have various shapes according to the trademark and model. The power board was modified, the heat sink

occupies all the height of the board and both relays have disappeared.

IX3WR allows piloting specific sources, such as the Krône inducer or the triple-crown inducer that justifies the presence of a relay on the board. **This relay is not a power distribution relay.**

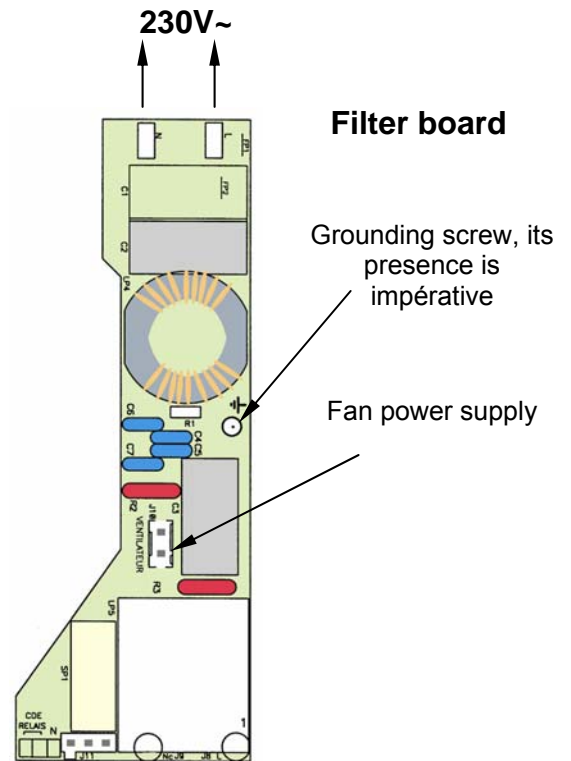

Power board

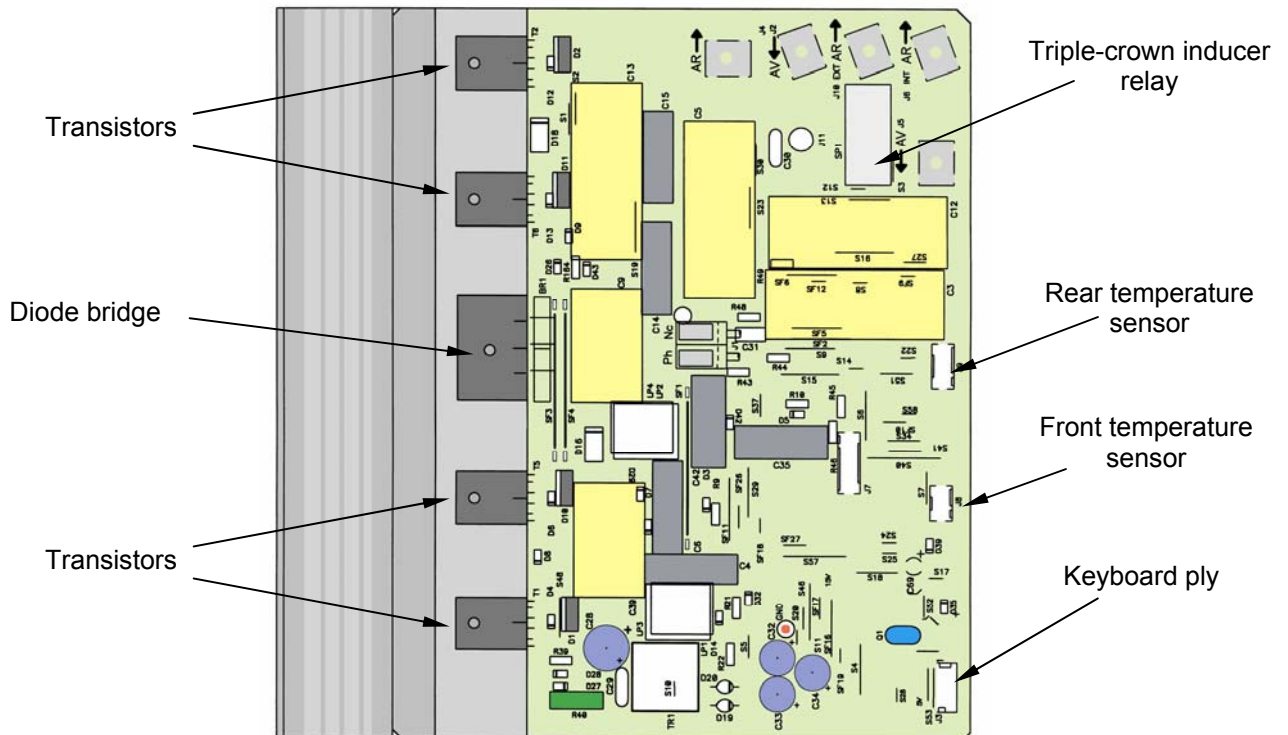

Standby consumption is under 1 Watts.

11.2. - Internal organization

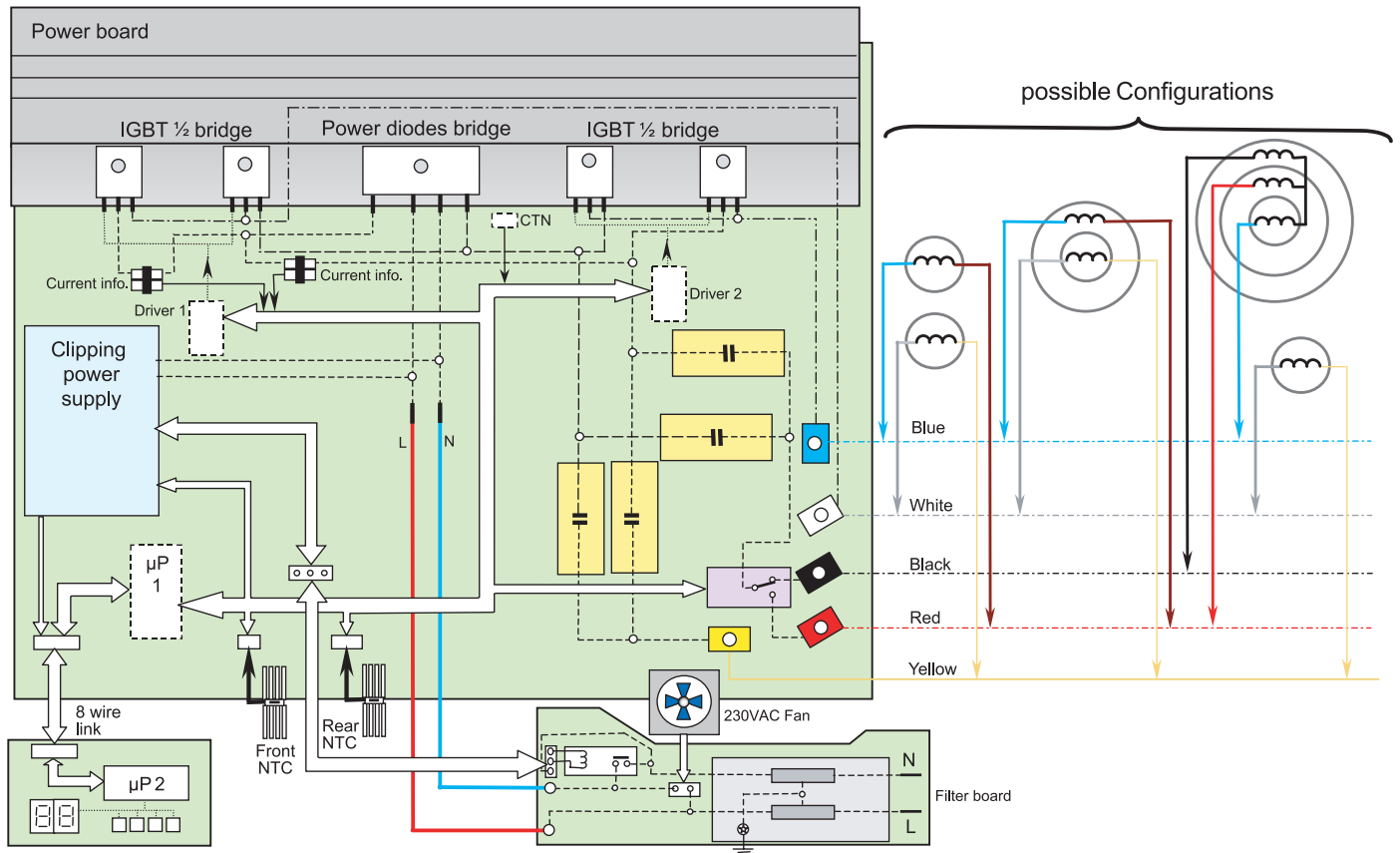

11.3. - Details of the power circuit

The IX3WR power circuit strongly differs from the IX3.

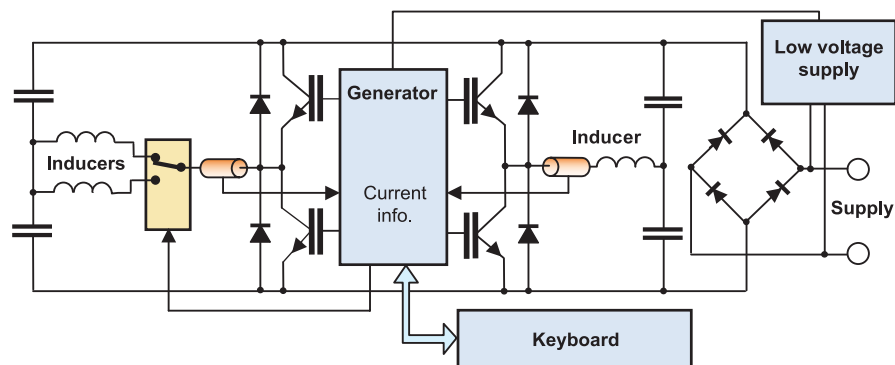

- Integrated rectifier bridge.
- The front / rear distribution by relay is replaced by the inverter stage doubling. The result is: 2 x 2 recovery diodes, 2 x 2 capacitors, 2 X 2 Transistors
- A current transformer by inverter to ensure saucepan detection.
- Use of IGBT transistors. The IGBT (**I**nulated **G**ate **B**ipolar **T**ransistor) is a bipolar transistor that is voltage controlled. It associates the advantages of bipolar transistors (high voltages and currents) and those of MOSFET transistors (high-speed switching, low control energy).
- A relay provides control of a 'triple crown' source.

12 - THE IX4000 HOBS

12.1. - Description

IX4000 is designed to meet the needs of range-bottom inductions. It replaces version IX3, and complements the IX3WR offer.

It is easily identified thanks to its characteristic lower air inlet and controls the standard and Krône sources.

Production start: October 2002.

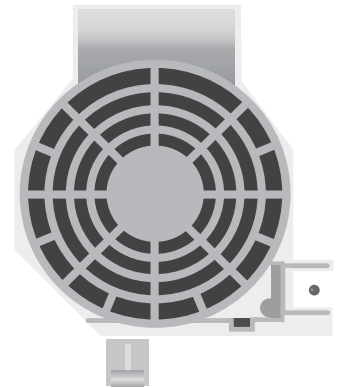

12.2. - Internal organization

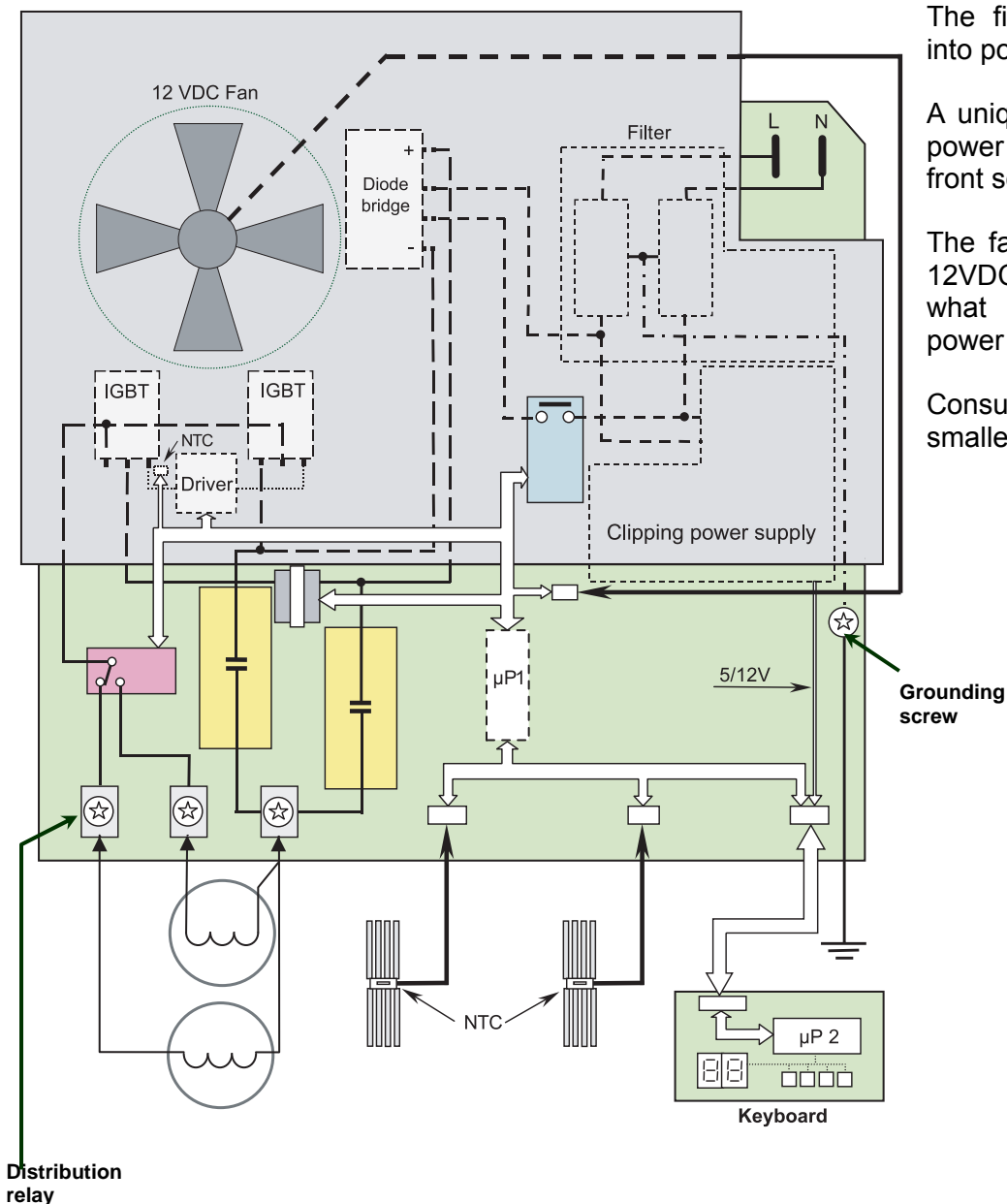

The filter board is integrated into power board.

A unique relay is used for the power distribution between front source and rear source.

The fan used is supplied with 12VDC and is comparable to what is used for computer power supplies.

Consumption in standby smaller than 1W.

Grounding screw

Distribution relay

Keyboard

12.3. - Details of the power circuit

The power circuit is inspired from both the IX3 hob (for the principle) and the IX3WR hob (for components).

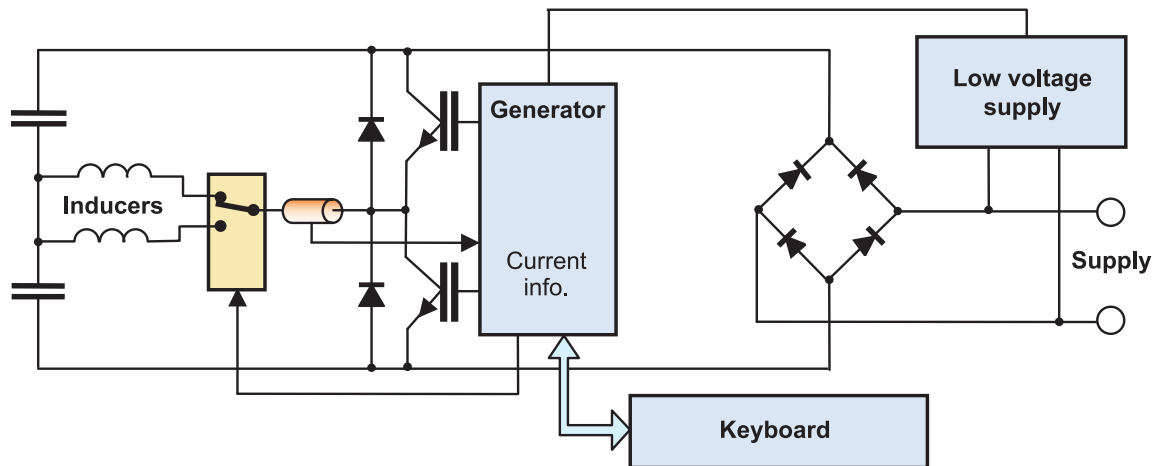

- Integrated rectifier bridge (located under dissipation sheet metal).
- Front / rear distribution ensured by a single relay.
- A current transformer ensures the saucepan detection.
- Use of IGBT transistors (**I**nulated **G**ate **B**ipolar **T**ransistor) for the inverter.

13 - THE IX6 HOBS

13.1. - Introduction

IX6 replace IX3WR electronic control, The air inlets are the same as IX4000. The cabinet has been modified to improve the air vacuum at the front and simply the fitting.

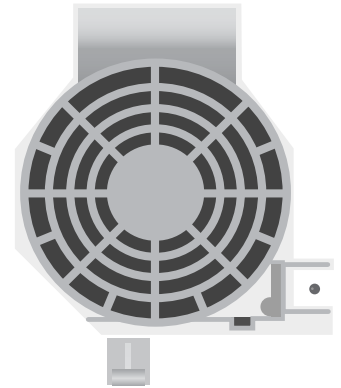
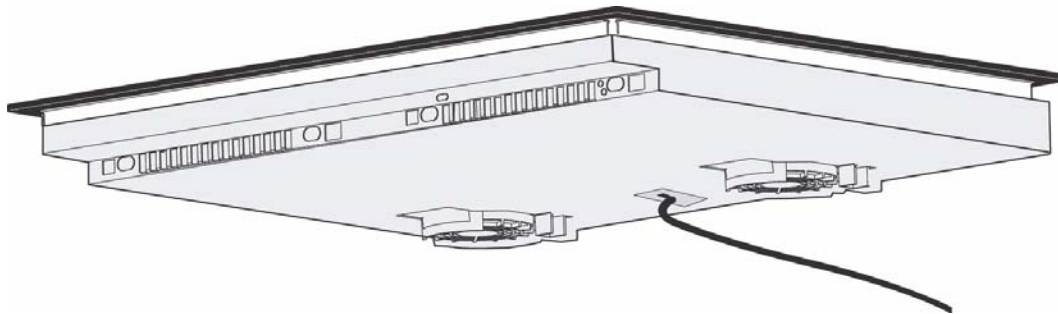

The IX6 hobs can be recognized by its only one board including a large radiator over the electronic. The keyboard can be different according to the brand and the model.

IX6 allows supplying all kinds of inducers. As IX3WR, IX6 includes a relay especially to manage triple-crown inducer. This relay doesn't manage the power distribution between 2 different inducers.

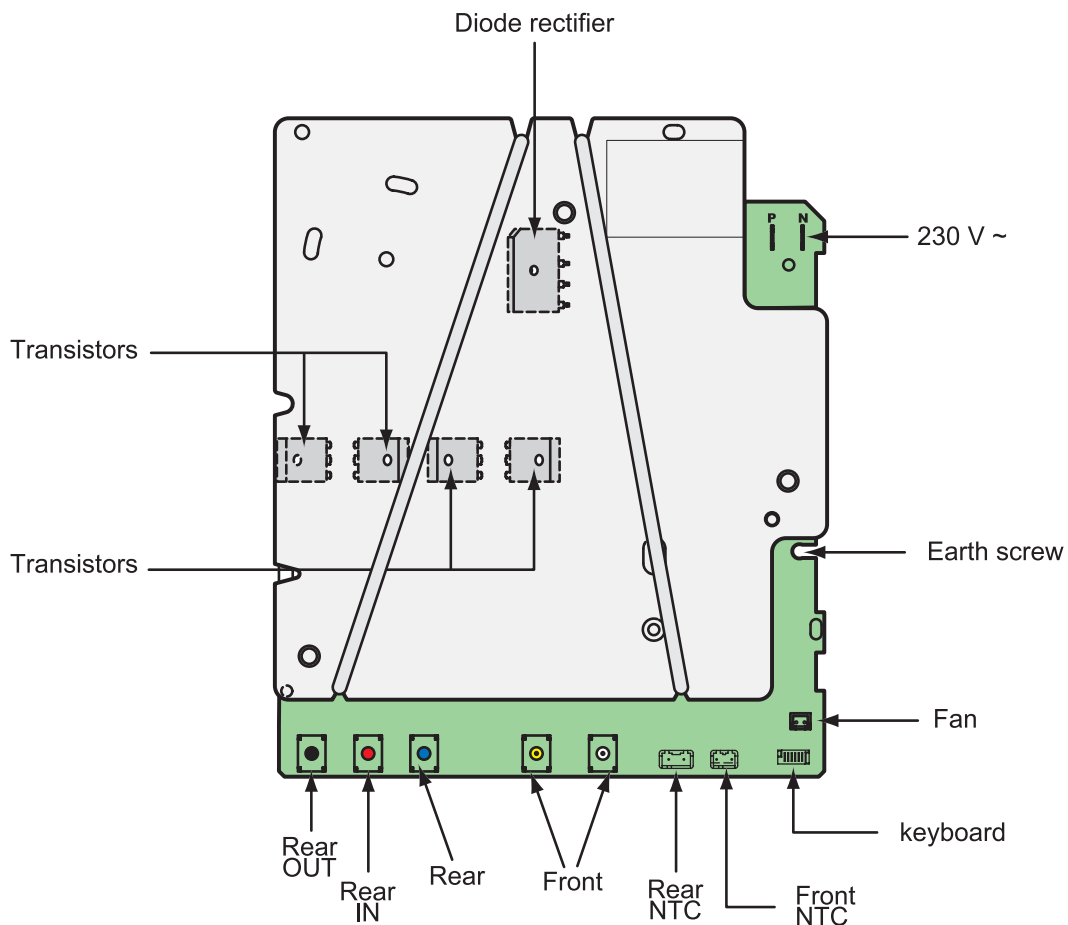

Standby consumption is under 1 Watt.

13.3. - Power circuit description

The power circuit uses the same principle as IX3WR (for the main components).

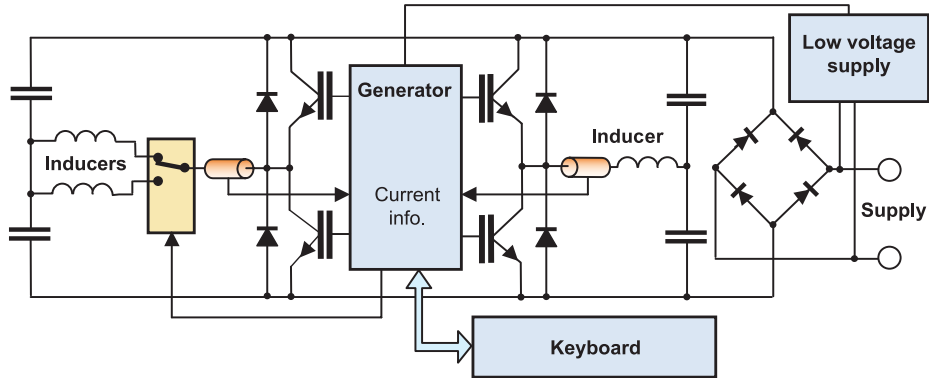

- 4 diodes rectifier
- The front / rear power distribution by relay is replaced by the inverter stage doubling. The result is: 2 x 2 recovery diodes, 2 x 2 capacitors, 2 X 2 Transistors
- A current transformer by inverter to ensure container detection.
- Use of IGBT transistors. The IGBT (Insulated Gate Bipolar Transistor) is a bipolar transistor that is voltage controlled. It associates the advantages of bipolar transistors (high voltages and currents) and those of MOSFET transistors (high-speed switching, low control energy).
- A relay provides control of a 'triple crown' source.

14 - AID TO DIAGNOSTIC

Prior The first step is to identify the symptom of the problem with the hob. To help you in your diagnostic, the hob displays a few dysfunction messages, remember that on each power-up, you have to wait a few seconds for it to start operating.

Ensure that the problem is not related to the use of a specific container, check in the "**Class Induction**" list that the container is part of it or check the "**lock-on**" by using a test container.

14.1. - The glass-ceramic breakages

Mechanical and thermal overloads cause very characteristic breakage profiles, which are different on principle, so that the cause is easy to detect.

The four main causes are:

- Overheating (on radiant / halogen source only)
- A shock on the hob
- A tight assembly
- A plate subjected to too significant a pressure (contraction)

In case of confusion, it is advisable to assemble the plate pieces with adhesive tape before disassembling the plate for assessment purposes.

14.1.1. - Breakage resulting from overheating

This type of breakage must not exist on an induction hob. Overheating causes breakage profiles, as shown by the two drawings of hob, each with a cooking area. Cracks of circular shape, that appear within the cooking area or at the edges, are very typical.

Breaks, such as shown by drawing A, appear more often at the beginning of cooking or during cooking. Breaks, such as shown by drawing after hob cooling down. Often, the user will say that the hob cracked during or after cooking without his/her intervening.

Causes: The regulation of the heating element is defective.

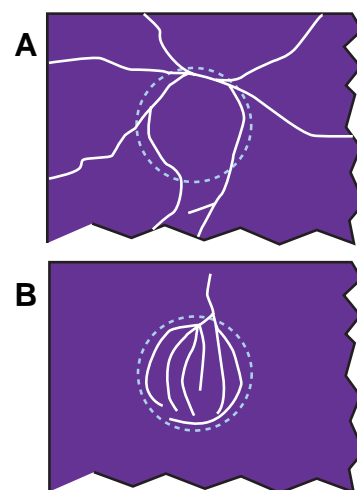

14.1.2. - Breakage resulting from a shock or knock

The break profile looks like a spider web. From the point of impact, radial cracks R start and divide the cooking surface area. Broken pieces are subdivided into several parts by circular cracks T around the place that received the knock. The number of pieces much depends on the shock strength.

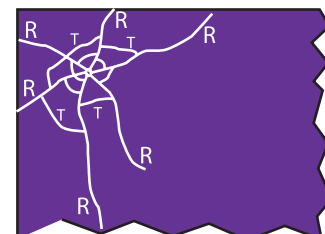

14.1.3. - Breakage resulting from a tight assembly

A tight assembly is due to bad flush mounting of the hob in the frame, or to bad assembly of the frame onto the hob.

This result in only few cracks, often only one, as shown by the two drawings. Regions of contractions (jamming) can be in a. b. or c. In some cases, cracks do not break completely the plate.

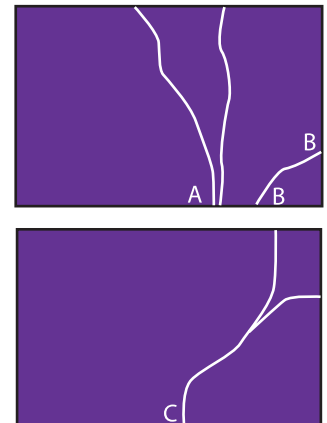

14.1.4. - Breakages due to the use of a container with a nonflat bottom

Containers with nonflat bottoms may cause a breakage. The container creates a hot point (The small point in the drawing) which fuses together the glass and the container itself. When one takes off the container, a piece of glass can be removed from the top.



The overheating point can be checked on the inducer screen.

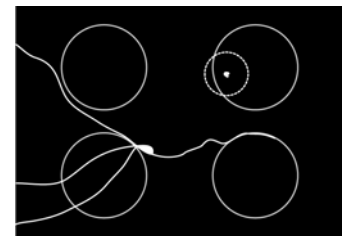

Containers with flat bottoms must be used

14.1.5. - Flush-mounted hob subjected to contractions

This type of break due to the fact that the hob is flush mounted too fit in the kitchen furniture, more often than not when edges of the working plane are not flat (e.g.: tiled plane).

It is typical in this type of break, that there is only one crack (a or b) parallel to one of the plate sides and approximately in the centre of this plate. In certain cases, the crack does not separate completely the hob.

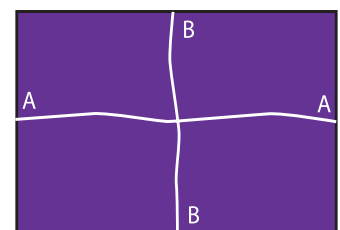

Precautions:

- Check the flatness of the flush-mounting surface.
- Do not tight too forcefully the hob when mounting it flush.

14.2. - The 'error' codes

'Error' codes are a precious aid to diagnostic. Take care to well identify the model to be troubleshooted, as codes do not always have the same meaning.

	IX3		IX3WR, IX4000 and IX6	
F0	NTC T°C < 5°C	Room too cold	Sans objet	
F1 F2	Front source: Pb of shorted NTC (F1) or open circuit (F2)	Check the assembly, connection and ohmic value of the NTC.	Front source: Pb of shorted NTC (F1) or open circuit (F2)	Check the assembly, connection and ohmic value of the NTC.
F3 F4	Rear source: Pb of shorted NTC (F3) or open circuit (F4)		Rear source: Pb of shorted NTC (F3) or open circuit (F4)	
F5 F6	Check of transistors: Pb of shorted NTC (F5) or open circuit (F6)	Replace the board, as NTC and transistors are interdependent	Check of transistors: Pb of shorted NTC (F5) or open circuit (F6)	Replace the board, as NTC and transistors are interdependent
F7	T°C of transistors > 70°C and of electronics > 105°C	Check the installation Check the ventilation.	T°C of electronics > 70°C. The message is followed by a crawler	Check the installation Check the ventilation.
F8	Reversal of front and rear NTC's	Check the crimping of NTC's on their comb, and the right assembly. If they are correct: Replace the board.	Reversal of front and rear NTC's	Check the crimping of NTC's on their comb, and the right assembly. If they are correct: Replace the board.
F9	Not applicable		Mains undervoltage Urms < 180V	Mains problem
 + BIP	Not applicable		Continuous pressure > 9s, which results in power cut and hob shutdown If the user acts on a non-covered key, the display is resumed after 1 min with a 'beep' every 8s and then stops.	Overflow problem or problem with keys covered by a container or other implement.

➤ **IX3WR crawler = Overheating of transistors and electronics.**



14.3. - Tests and measurements on IX3, IX3WR, IX4000 and IX6

Where the action on the board is not desired, the diagnostic will be limited to the defective element. Any action on the circuit shall be carried out after eliminating the causes that may be due to saucepans or to a bad installation.

To avoid damaging the electronic components, never touch the circuit with your fingers.

CAUTION : It is necessary to reinstall the glass-ceramic top to conduct the tests.

14.3.1. - The test keyboards

During a diagnostic, it is necessary to know whether it is the control keyboard or the power board, which is defective. However, you must not omit the filter board, which includes two fuse pads and the power supply relay. Generations IX3 on the one hand and IX3WR, IX4000, IX6 on the other hand do not use the same encoding process. It is therefore advisable to be provided with two different test keyboards.

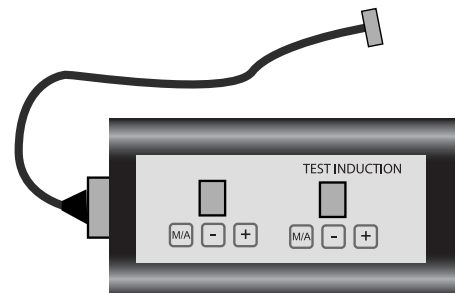

- IX3 keyboard: **79X5460**
- IX3WR, IX4000 and IX6 keyboards: **79X9920**

This keyboard will enable all the keyboard of each range to be replaced. In event of degradation with use, baseplates can be replaced:

- 6-point baseplate (IX3) : **79X5461**
- 8-point baseplate (IX3WR, IX4000, IX6) : **79x9921**

14.3.2. - The IX3 and IX3WR filter board

These two generations have a different control but use the same filter board. This board includes:

- A direct output for the control power supply
- A relay for the power supply
- Two fuse pads
- The fan power supply (via the relay).

In event of problem with power supply, it is advised to check:

- Whether 'fuse' pads are out of order
- Whether the power relay is controlled (12VDC)
- Whether the relay delivers 230VAC to the board.
- Whether the relay delivers 230VAC to the fan

Note: Fuse pads are also present on the IX6 and IX4000 boards.

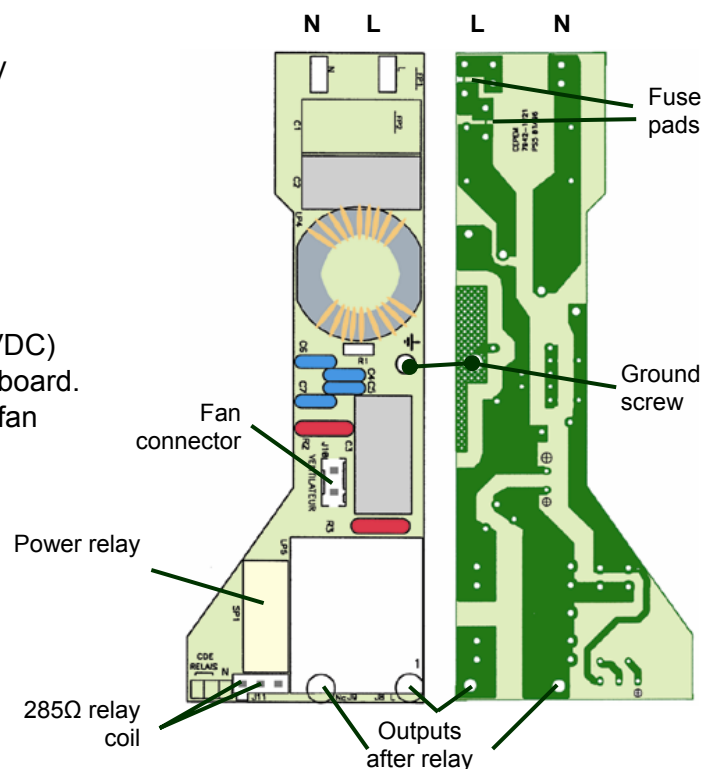

14.3.3. - Measurements on IX3 power board

These test points are used to check whether the independent filter board

- delivers a voltage for the control supply
- delivers a voltage for the power supply
- power relay is controlled by the command

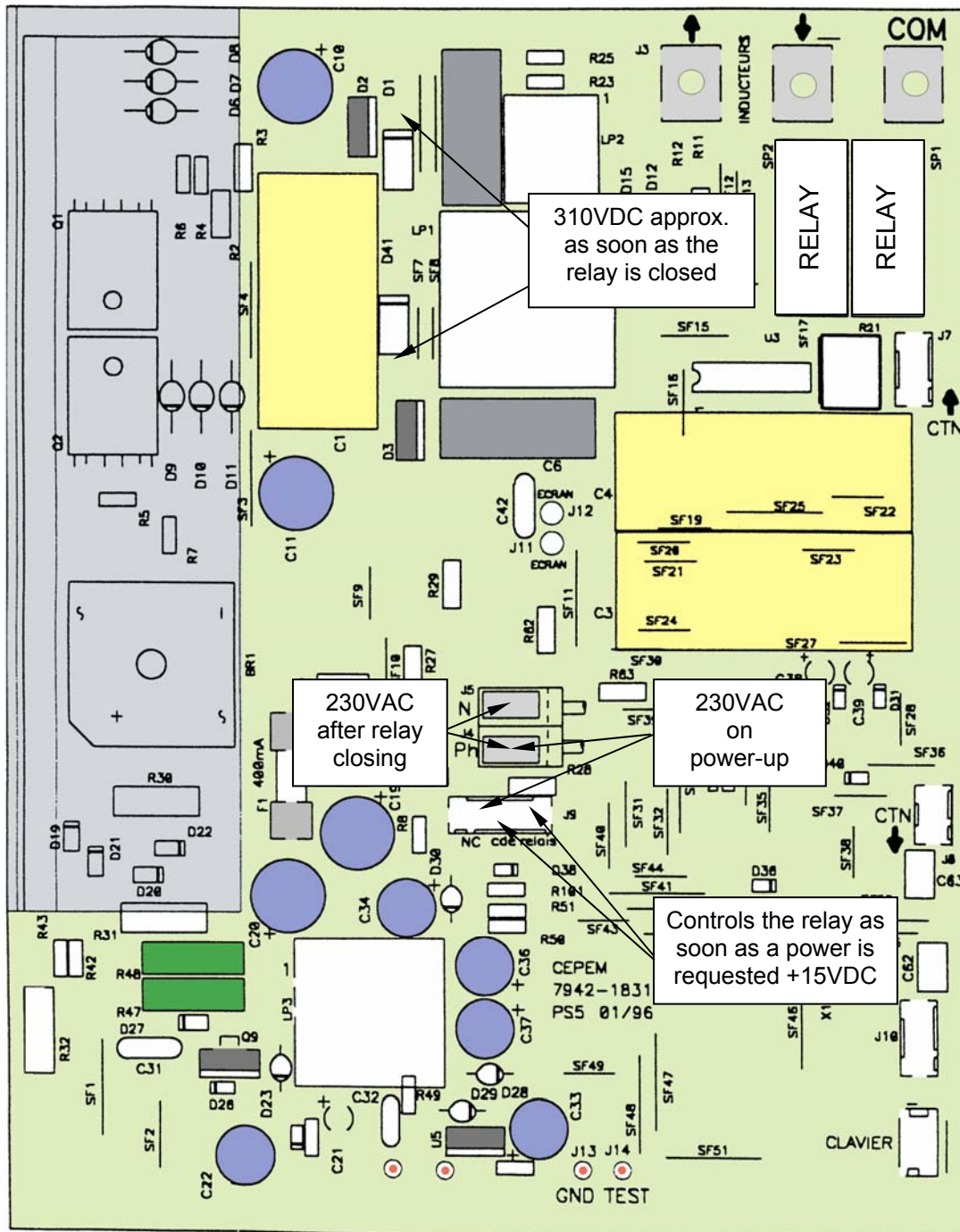

14.4. - Measurements and checks on IX3 WR power board

These test points are used to check whether the independent filter board

- delivers a voltage for the control supply
- delivers a voltage for the power supply
- power relay is controlled by the command

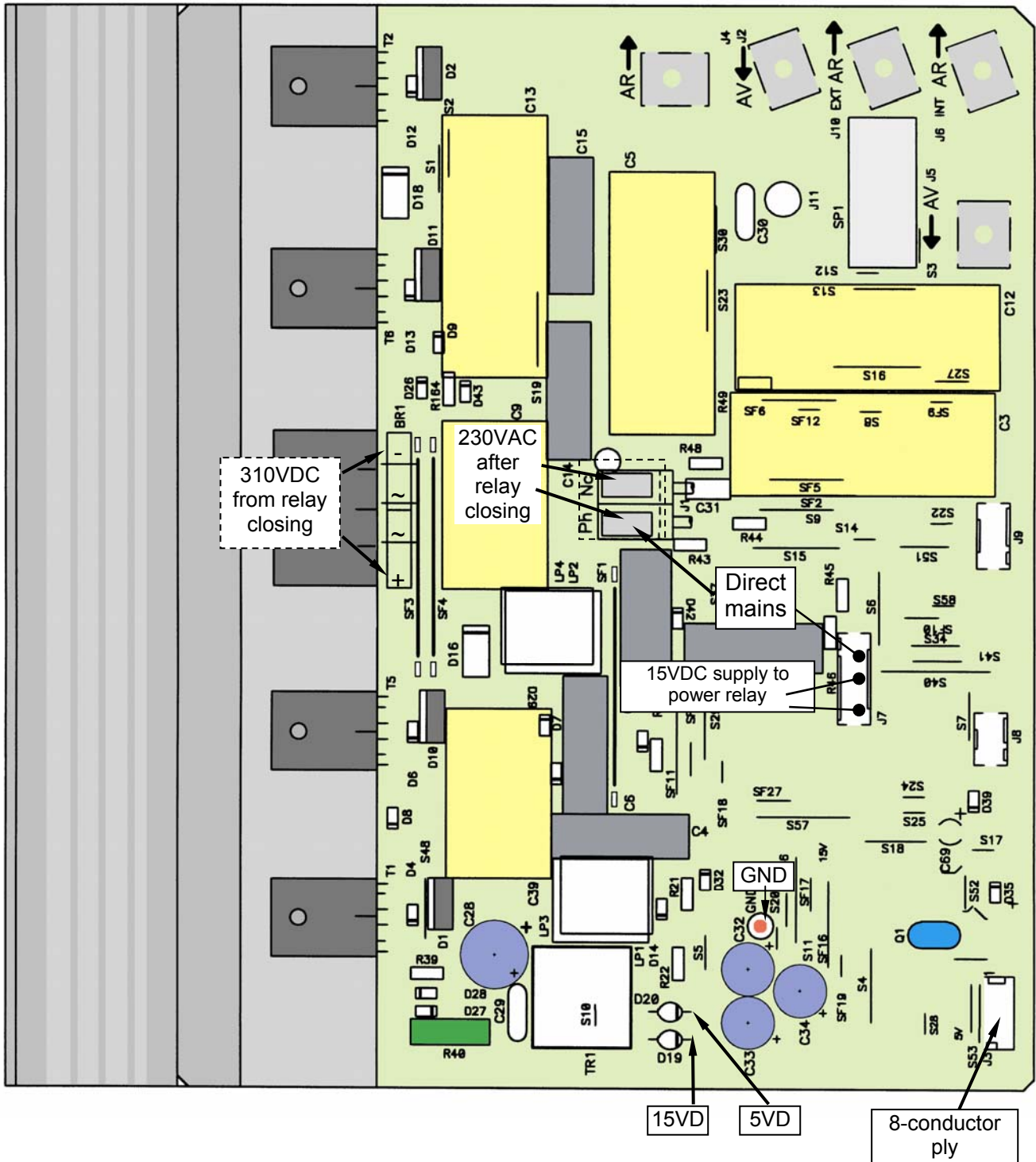

14.5. - Troubleshooting advice (IX3, IX3WR and IX4000)

It is difficult to supply a troubleshooting chart since causes are numerous. Within the framework of an After-sales Department action, the reasoning will be limited to identify which of the components (Control board, filter board, keyboard, inducer, fan ...) is faulty without trying to act on the component itself (Replacement of components).

Achieving a correct component relies on the use of the test keyboards available at B.C.S.'s

For each case of failure, it will be advisable to ask the appropriate questions and use the test points provided by this document to answer them.

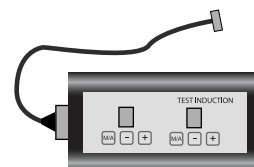
**Control dysfunction**

→ Systematic use of the test keyboard (two references)

Control dysfunction with the test keyboard

- Is the filter board powered? (IX3 and IX3WR)
- Is the power board powered?
- Is the power relay (located on filter board) controlled? (IX3 and IX3WR)
- Does the power relay (fan start-up) switch on ? (IX3 and IX3WR)

These checks are used to determine which of the 'filter' or 'power' boards is out of order.

Ventilation dysfunction

- In case of 'overheating error' message, check if the installation is correct ?
- Is the fan mechanically locked?
- Is the fan powered? (12VDC or 230VAC according to model)

In event of dysfunction on only one inducer

- First, check the connection between power board and inducer.
- Is the distribution relay controlled (Clic-Clac)? (IX3, IX4000)
- Is there a lock-on problem on one of the sources? (IX3WR, IX6)

Recall: The 'inverter and detection' staged is backed-up on IX3WR and IX6 boards.

In event of saucepan non-detection

- Does the saucepan pass the magnet test?
- Does the saucepan appear in the 'Class induction' list?
- Does the saucepan have the required minimum diameter (12cm, generally)?



Brandt Customer Services
BP 69526– 95060 CERGY-PONTOISE CEDEX
SAS au capital de 2.500.00 € - RCS Pontoise B 440 303 303 - SIRET 440 303 303 00026 - APE 514F
Service formation : Agrément N° 11 95 00 685 95 - Fax : 33 (0)1 34 30 68 42 - E-mail : formationtechnique@elcobrandt.com