

5V_STB电路

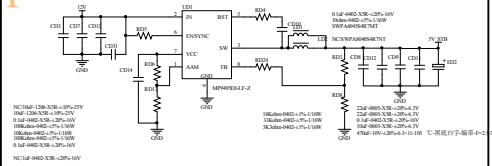

5V_M电路

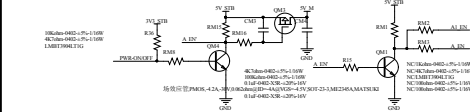

核供电电路1

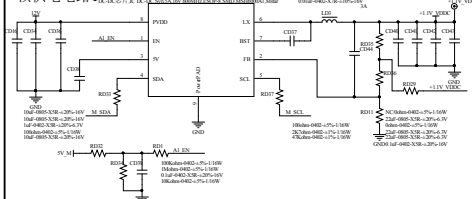

核供电电路2

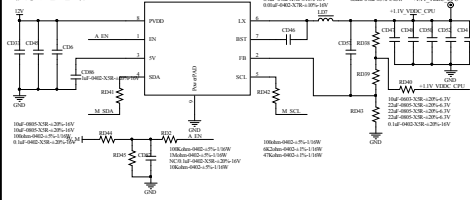

3V3_WIFI

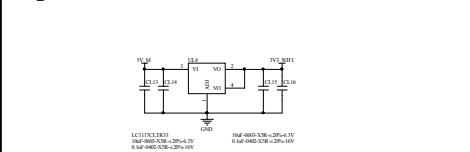

3V3_Tun

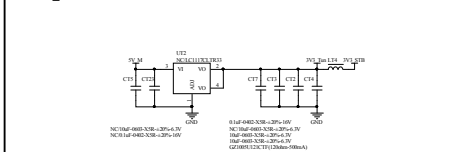

eMMC FLASH

U1002 EMMC FLASH 芯片,4GB,MLC,BGA153,SMD,H2613 001HPR,Sk-Hynix

NF CLK	M6	CLK	D4	B3	NF D4
NF CMD	M5	CMD	D5	B4	NF D5
NF D0	A3	D0	D6	B5	NF D6
NF D1	A4	D1	D7	B6	NF D7
NF D2	A5	D2			
NF D3	B2	D3			
		RESET	K5	NF RSTZ	

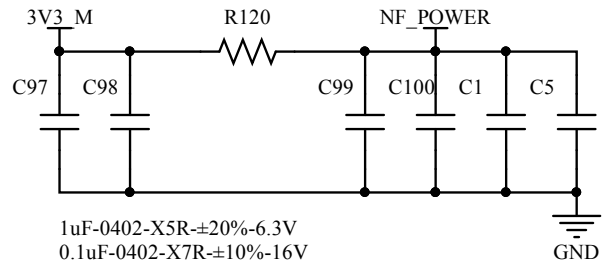
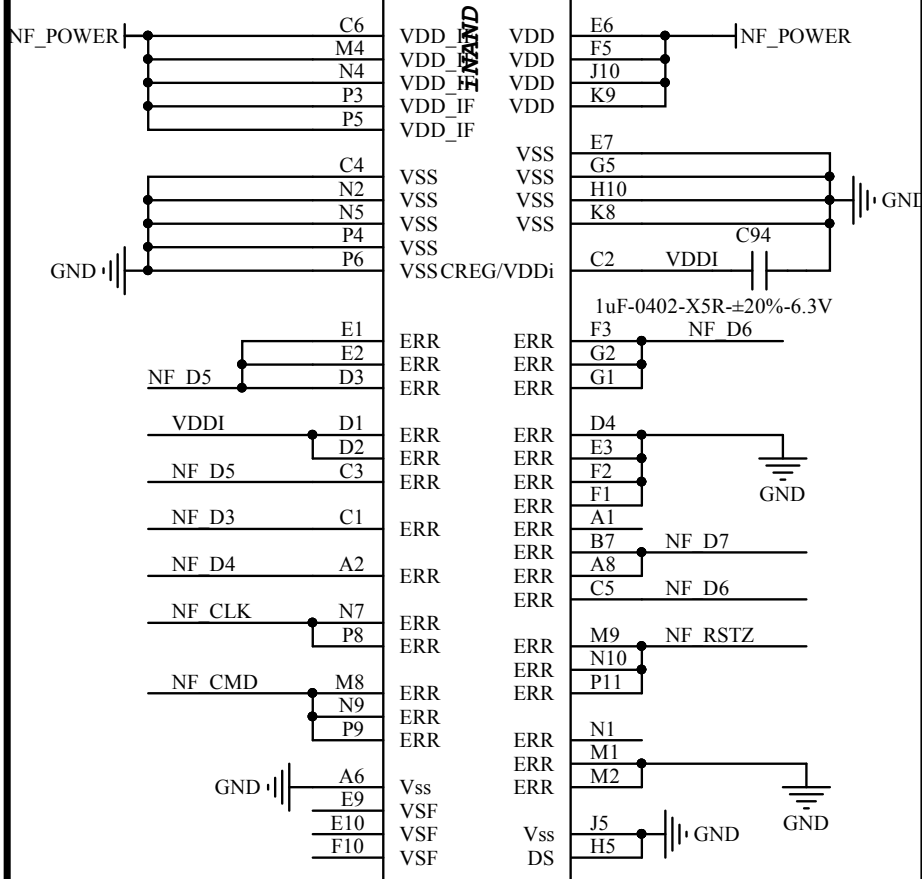

- 1uF-0402-X5R-±20%-6.3V
- 0.1uF-0402-X7R-±10%-16V
- 0ohm-0402-±5%-1/16W
- 1uF-0402-X5R-±20%-6.3V
- 0.1uF-0402-X7R-±10%-16V
- 0.1uF-0402-X7R-±10%-16V
- 0.1uF-0402-X7R-±10%-16V

- 22ohm-0402-±5%-1/16W
- 0ohm-0402-±5%-1/16W
- 0ohm-0402-±5%-1/16W

NF CLK	R111	EMMC CLK
NF CMD	R113	EMMC CMD
NF RSTZ	R115	EMMC RSTZ

NF D0	1	2	EMMC D0
NF D1	3	4	EMMC D1
NF D2	5	6	EMMC D2
NF D3	7	8	EMMC D3
			4*0ohm-0402-±5%-1/16W
NF D4	7	8	EMMC D4
NF D5	5	6	EMMC D5
NF D6	3	4	EMMC D6
NF D7	1	2	EMMC D7
			4*0ohm-0402-±5%-1/16W

KEY&IR&LED

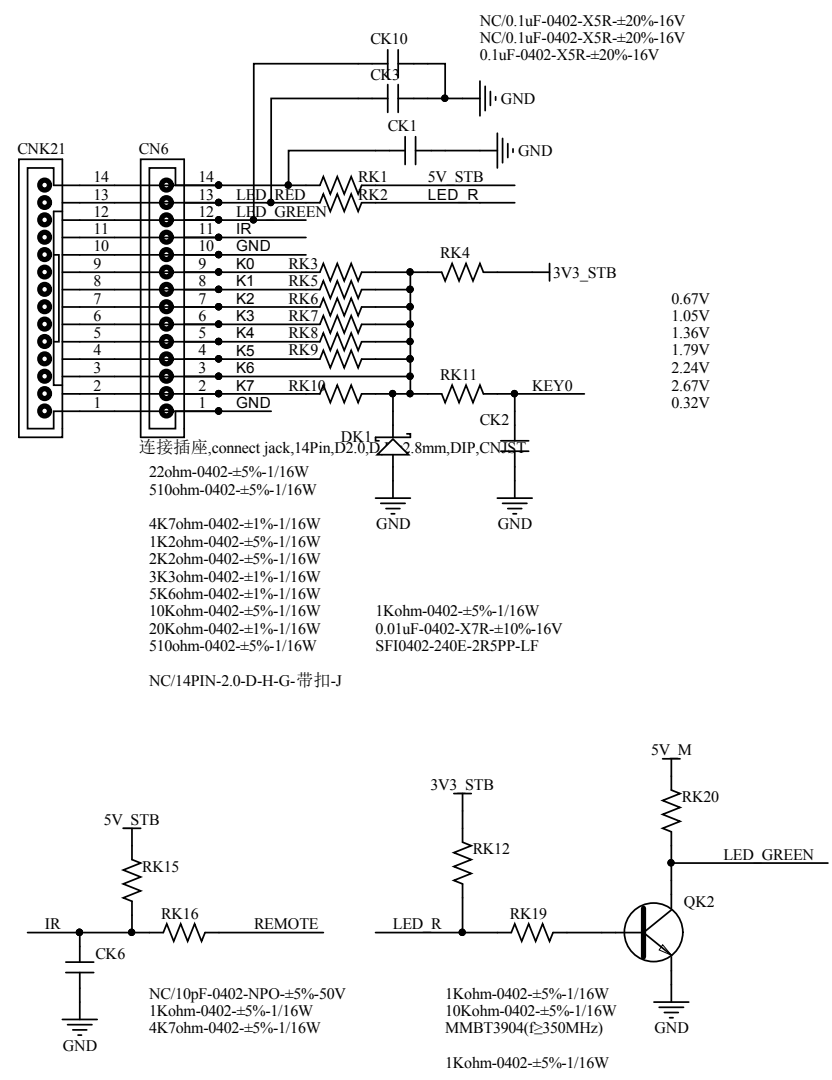

PANEL 驱屏电压

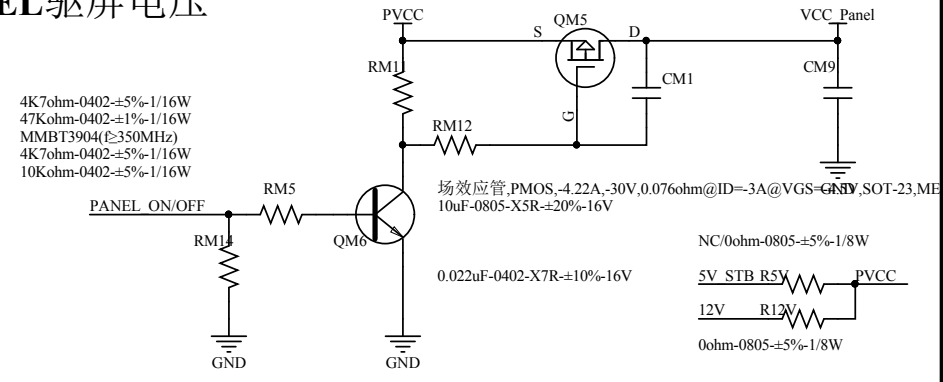

LVDS

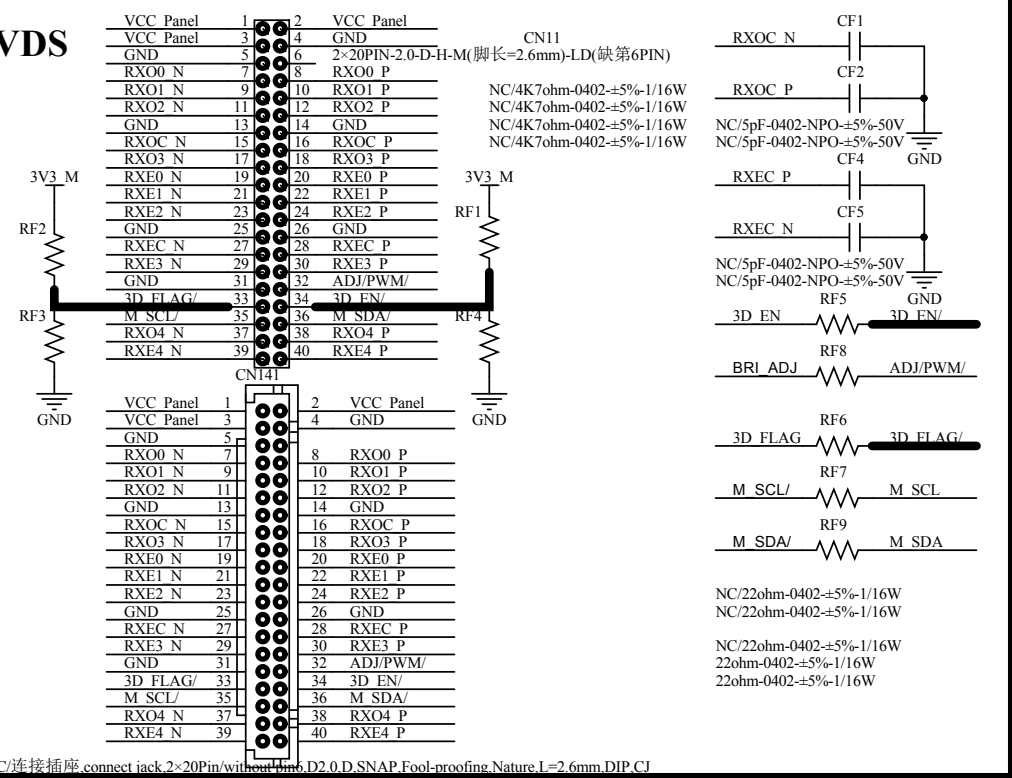

1 2 3 4 5 6

AV_OUT&COAX

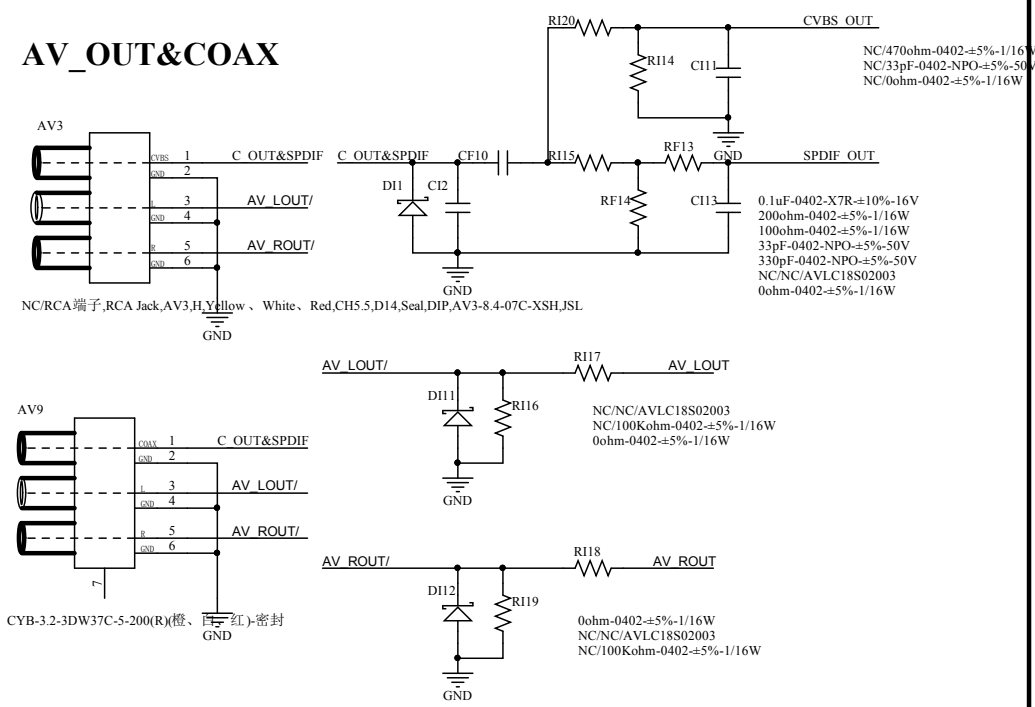

YPBPR&AUDIO IN&COAX

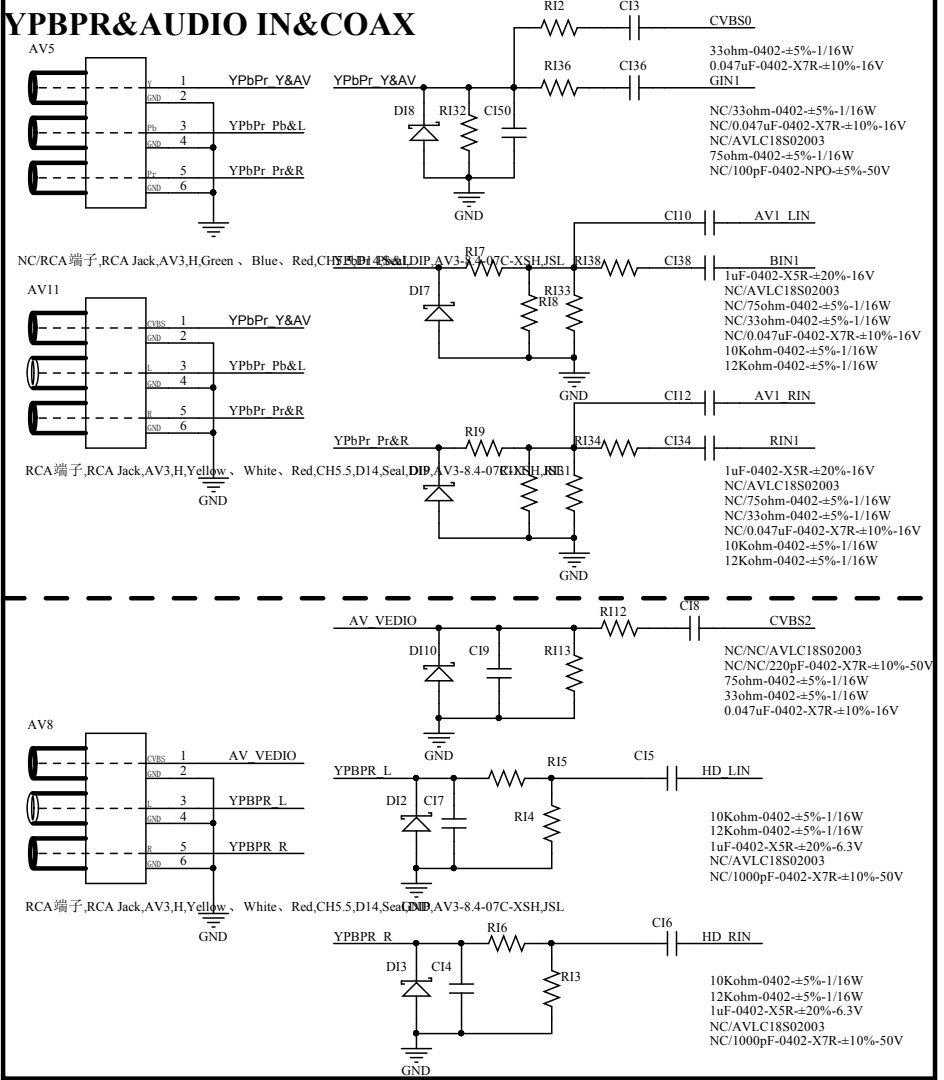

1 2 3 4 5 6

A
B
C
D

A
B
C
D

TUNER

